

LP SOLIDSTART I-JOISTS LIGHT-FRAME COMMERCIAL AND MULTIFAMILY CONSTRUCTION U.S. TECHNICAL GUIDE

LPI® 36, 42Plus, 52Plus and 56 Series

LP **SolidStart**®
ENGINEERED WOOD



U.S. Technical Guide

Please verify availability with the LP SolidStart Engineered Wood Products distributor in your area prior to specifying these products.

Introduction

Light-Frame Commercial and Multifamily Building Products from LP Building Products.

LP® SOLIDSTART® ENGINEERED WOOD PRODUCTS. ADVANTAGES YOU CAN USE.

LP SolidStart Engineered Wood Products provide solid, true and uniform building solutions for not only residential construction but for light-frame commercial and multifamily projects as well.

Our products deliver sustainability benefits and cost efficiencies that traditional lumber can't match. They offer superior strength, durability and consistency. They cut and work just like traditional wood. And they resist cupping, warping, twisting and shrinking. So you save time and money during construction while delivering advantages your customers will enjoy for years to come.

This guide features design information especially for builders using our engineered wood products in light-frame commercial and multifamily construction.

LIFETIME LIMITED WARRANTY

LP SolidStart Engineered Wood Products are backed by a lifetime limited warranty. Visit LPCorp.com or call 1.888.820.0325 for a copy of the warranty.



Table of Contents

Product Specifications: Design Values	4
Product Specifications: Reaction Capacity	5
Uniform Floor Load (PLF) Tables	6-13
Floor Details	14-15
Web Stiffeners	16
Web Hole Specifications	17
Web Hole Specifications: Circular Holes	18
Web Hole Specifications: Rectangular Holes	19
Roof Span Tables: Low Pitch (6:12 or less)	20-21
Roof Span Tables: High Pitch (6:12 to 12:12)	22-23
Uniform Roof Load (PLF) Tables	24-31
Roof Details	32
Sprinkler Details	33
LP® SolidStart® OSB Rim Board	34
Warnings	35
Handling and Storage Guidelines	36



Product Specifications: Design Values

DESIGN VALUES						
Series	Depth	Weight	Moment	EI (x 10 ⁶)	K (x 10 ⁶)	Shear
		(plf)	(lb-ft)	(lb-in ²)	(lb-ft/in)	(lbs)
LPI 36	11-7/8"	3.1	6445	429	0.468	1615
	14"	3.4	7755	622	0.550	1830
	16"	3.6	8995	836	0.625	2020
	18"	3.9	10135	1082	0.700	2185
LPI 42Plus	11-7/8"	3.5	6965	547	0.515	1625
	14"	3.8	8390	802	0.607	1875
	16"	4.0	9725	1092	0.693	2115
	18"	4.4	11000	1333	0.960	2555
	20"	4.6	12170	1688	1.067	2795
	24"	5.5	14480	2534	1.280	3270
LPI 52Plus	11-7/8"	4.5	8475	600	0.633	2055
	14"	4.8	10205	874	0.747	2330
	16"	5.0	11835	1183	0.853	2585
LPI 56	11-7/8"	4.5	10170	668	0.549	2055
	14"	4.8	12250	968	0.641	2330
	16"	5.0	14205	1301	0.729	2585
	18"	5.3	16010	1684	0.817	2845
	24"	6.0	21340	3127	1.081	3620

NOTES:

1. LP® SolidStart® I-Joists shall be designed for dry-use conditions only. Dry-use applies to products installed in dry, covered and well ventilated interior conditions in which the equivalent moisture content in lumber will not exceed 16%.
2. Moment and Shear are for normal load duration and shall be adjusted according to code.
3. Moment shall not be increased for repetitive member use.
4. Deflection calculations shall include both bending and shear deformations.

Deflection for a simple span, uniform load: $\Delta = \frac{22.5wL^4}{EI} + \frac{wL^2}{K}$ Where: Δ = deflection (in) EI = bending stiffness (from table)
 w = uniform load (plf) K = shear stiffness (from table)
 L = design span (ft)

Equations for other conditions can be found in engineering references.

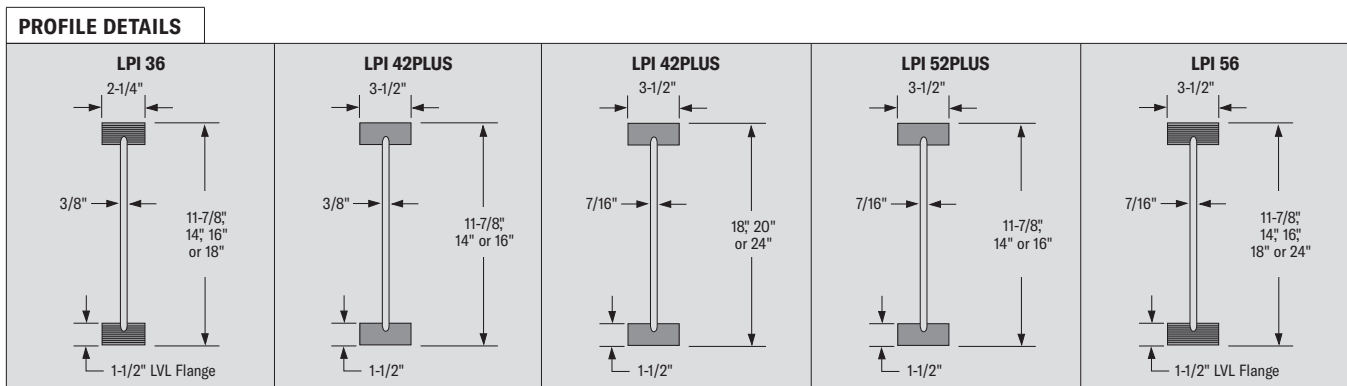

Product Specifications: Reaction Capacity

REACTION AND BEARING CAPACITY											
Series	Depth	End Reaction Capacity (lbs) ¹					Interior Reaction Capacity (lbs) ¹				Flange Bearing Capacity ² (lb/in)
		Minimum Bearing (see below)			Maximum Bearing (4")		Minimum Bearing (3-1/2")		Maximum Bearing (5-1/2")		
		W/out Stiffeners	With Stiffeners	Bearing Length	W/out Stiffeners	With Stiffeners	W/out Stiffeners	With Stiffeners	W/out Stiffeners	With Stiffeners	
LPI 36	11-7/8"	1025	1500	1-1/2"	1290	1615	2500	3105	2835	3470	1185
	14"	1025	1515	1-1/2"	1325	1830	2500	3205	2835	3565	
	16"	1025	1525	1-1/2"	1360	2020	2500	3305	2835	3655	
	18"	1175	1800	2-1/2"	1395	2185	2500	3405	2835	3750	
LPI 42Plus	11-7/8"	1245	1510	1-1/2"	1595	1625	3025	3340	3120	3515	1705
	14"	1300	1660	1-1/2"	1595	1875	3140	3565	3280	3805	
	16"	1350	1800	1-1/2"	1595	2115	3245	3775	3435	4080	
	18"	1500	2305	2-1/2"	1690	2555	3450	4285	3850	4625	
	20"	1500	2450	2-1/2"	1690	2795	3450	4410	3850	4835	
24"	1500	2705	2-1/2"	1690	3270	3450	4640	3850	5210		
LPI 52Plus	11-7/8"	1370	1820	1-1/2"	1690	2055	3420	4000	3635	4210	2000
	14"	1385	1970	1-1/2"	1845	2330	3435	4260	3745	4540	
	16"	1400	2110	1-1/2"	1985	2585	3450	4505	3850	4855	
LPI 56	11-7/8"	1145	1660	1-1/2"	1515	2055	3130	3860	3670	4060	1870
	14"	1145	1755	1-1/2"	1535	2330	3130	4055	3670	4300	
	16"	1145	1845	1-1/2"	1555	2585	3130	4245	3670	4525	
	18"	1315	2300	2-1/2"	1575	2845	3130	4435	3670	4750	
	24"	1340	2770	2-1/2"	1635	3620	3130	5000	3670	5430	

NOTES:

- End and Interior Reaction Capacity shall be limited by the Flange Bearing Capacity or the bearing capacity of the support material, whichever is less.
- The Flange Bearing Capacity, per inch of bearing length, is based on the allowable compression perpendicular-to-grain of the I-Joist flange, accounting for eased edges.
- To account for edge easing when determining the bearing capacity of the support material, subtract 0.25" from the flange width for the LPI 42Plus & LPI 52Plus, and subtract 0.10" from the flange width for the LPI 36 & LPI 56.
- Reaction Capacity is for normal load duration and shall be adjusted according to code. Flange Bearing Capacity and the bearing capacity of any wood support shall not be adjusted for load duration.
- Reaction Capacity and Flange Bearing Capacity may be increased over the values tabulated for the minimum bearing length. Linear interpolation of the Reaction Capacity between the minimum and maximum bearing length is permitted. Bearing lengths longer than the maximum do not further increase Reaction Capacity. Flange Bearing Capacity and that of a wood support will increase with additional bearing length.
- See page 16 for information on web stiffeners sizes and nailing.

EXAMPLE:

Determine the stiffened end reaction capacity for a 16" LPI 42Plus with 2" of bearing for a non-snow roof load and supported on an SPF wall plate.

- Determine End Reaction (ER) w/ Stiffeners:
 $ER = 1800 + (2115 - 1800) * (2" - 1.5") / (4" - 1.5") = 1863 \text{ lbs}$
- Adjust for load duration: Adjusted ER = $1863 * 1.25 = 2328 \text{ lbs}$
- Determine Flange Bearing Capacity (FBC):
 $FBC = 1705 \text{ lb/in} * 2" = 3410 \text{ lbs}$
- Determine wall plate bearing capacity (PBC):
 $PBC = 425 \text{ psi} * (3.5" - 0.25") * 2" = 2762 \text{ lbs}$
- Final End Reaction Capacity w/Stiffeners = 2328 lbs

Uniform Floor Load (PLF) Tables: LPI 36 Simple Spans

TO USE:

1. Select the span required.
2. Compare the design total load to the Total Load column. Where two numbers are shown, the first number represents the Total Load capacity without web stiffeners. The second number represents the Total Load capacity with stiffeners. (See Additional Notes below.)
3. Compare the design live load to the appropriate Live Load column.
4. Select a product that exceeds both the design total and live loads.
5. Specify web stiffeners as dictated by the Total Load column.
6. Concentrated loads, where required, shall be evaluated by the designer.

EXAMPLE:

An I-Joist has the simple clear span of 18'-6", supporting 50 psf Floor Load and 25 psf Dead Load, spaced 24" oc. Select the shallowest joist that satisfies an L/600 live load deflection limit.

1. Select the row corresponding to a 19' span.
2. Design Total Load = $(50 + 25) * (24 / 12) = 150$ plf
Design Live Load = $50 * (24 / 12) = 100$ plf
3. Select the first joist to exceed both Total Load and L/600:

The 18" LPI 36 supports 185 plf Total Load and 114 plf Live Load at L/600

NOTE: Web stiffeners required at both end supports.

Span (ft)	11-7/8" LPI 36				14" LPI 36				16" LPI 36				Span (ft)
	Live Load			Total Load	Live Load			Total Load	Live Load			Total Load	
	L/600	L/480	L/360		L/600	L/480	L/360		L/600	L/480	L/360		
12'	166	208		171 / 246	230			171 / 251				172 / 256	12'
13'	135	169	226	158 / 227	188			158 / 232				159 / 236	13'
14'	111	139	186	147 / 211	156	195		147 / 216	202			148 / 220	14'
15'	93	116	155	137 / 197	130	163		137 / 202	169			138 / 205	15'
16'	78	97	130	129 / 185	110	137	183	129 / 189	143	179		130 / 193	16'
17'	66	83	110	121 / 166	93	117	156	122 / 178	122	153		122 / 182	17'
18'	56	70	94	115 / 141	80	100	133	115 / 169	105	131		115 / 172	18'
19'	48	61	81	109 / 122	69	86	115	109 / 160	91	113	151	109 / 163	19'
20'	42	52	70	103 / 105	60	75	100	103 / 150	79	99	132	104 / 155	20'
21'	36	46	61	92	52	65	87	99 / 131	69	86	115	99 / 147	21'
22'	32	40	54	81	46	57	76	94 / 115	61	76	101	95 / 141	22'
23'	28	35	47	71	40	50	67	90 / 101	53	67	89	90 / 134	23'
24'	25	31	42	63	36	45	60	86 / 90	47	59	79	87 / 119	24'
25'	22	28	37	56	32	40	53	80	42	53	71	83 / 106	25'
26'	-	-	-	-	28	36	48	72	38	47	63	80 / 95	26'
27'	-	-	-	-	25	32	43	64	34	42	57	77 / 85	27'
28'	-	-	-	-	23	29	38	58	31	38	51	74 / 77	28'
29'	-	-	-	-	21	26	35	52	28	35	46	70	29'
30'	-	-	-	-	19	23	31	47	25	31	42	63	30'
31'	-	-	-	-	-	-	-	-	23	28	38	57	31'
32'	-	-	-	-	-	-	-	-	21	26	35	52	32'
33'	-	-	-	-	-	-	-	-	19	24	32	48	33'
34'	-	-	-	-	-	-	-	-	17	22	29	44	34'
35'	-	-	-	-	-	-	-	-	-	-	-	-	35'
36'	-	-	-	-	-	-	-	-	-	-	-	-	36'
37'	-	-	-	-	-	-	-	-	-	-	-	-	37'
38'	-	-	-	-	-	-	-	-	-	-	-	-	38'

Span (ft)	18" LPI 36			Total Load	Span (ft)
	L/600	L/480	L/360		
12'				189 / 289	12'
13'				175 / 268	13'
14'				163 / 249	14'
15'	210			152 / 233	15'
16'	179			143 / 219	16'
17'	153	191		134 / 206	17'
18'	131	164		127 / 195	18'
19'	114	142		121 / 185	19'
20'	99	124	166	115 / 176	20'
21'	87	109	145	109 / 168	21'
22'	77	96	128	104 / 160	22'
23'	68	85	113	100 / 150	23'
24'	60	75	101	96 / 138	24'
25'	54	67	90	92 / 127	25'
26'	48	60	80	88 / 118	26'
27'	43	54	72	85 / 109	27'
28'	39	49	65	82 / 98	28'
29'	35	44	59	79 / 89	29'
30'	32	40	54	77 / 81	30'
31'	29	36	49	73	31'
32'	26	33	44	67	32'
33'	24	30	41	61	33'
34'	22	28	37	56	34'
35'	20	26	34	52	35'
36'	19	24	32	48	36'
37'	17	22	29	44	37'
38'	16	20	27	41	38'

DESIGN ASSUMPTIONS:

1. Span is the clear distance between supports for simple span applications only.
2. The values in the tables are for uniform loads only. Concentrated loads, where required, shall be evaluated by the designer.
3. Total Load is for normal (100%) duration.
4. These tables do not reflect any additional stiffness provided by the floor sheathing.
5. Live Load deflection is limited to L/360, L/480 or L/600 as noted in the table.
6. Total Load deflection is limited to L/240. Long term deflection (creep) has not been considered.
7. These tables assume full lateral support of the compression flange (maximum unbraced length of 24").
8. The spans are based on an end bearing length of at least 1-3/4" for depths up to 16" and at least 2-1/2" for depths greater than 16", and are limited to the bearing capacity for an SPF wall plate ($F_{cL} = 425$ psi).

ADDITIONAL NOTES:

1. The allowable loads represent the capacity of the joist in pounds per lineal foot (plf) of length.
2. The designer shall check both the Total Load and the appropriate Live Load column.
3. To design a double I-Joist, the values in these tables can be doubled, or the design loads on the I-Joist may be halved to verify the capacity of each ply. The capacity is additive. See Double I-Joist Connection detail on page 15.
4. Web stiffeners are not required where only one value is shown for Total Load or when the design total load does not exceed the first value (capacity without stiffeners) in the Total Load column where two values are given. Web stiffeners are required at both end supports if the design total load exceeds the first value. Do not exceed the second value (capacity with stiffeners).
5. Web fillers are required for I-Joists seated in hangers that do not laterally support the top flange or for hangers that require nailing into the web.
6. Where the Live Load is blank, the Total Load governs the design.
7. Do not use a product where designated "-" without further analysis by a design professional.

Uniform Floor Load (PLF) Tables: LPI 36 Continuous Spans

TO USE:

1. Select the span required.
2. Compare the design total load to the Total Load column. Where two numbers are shown, the first number represents the Total Load capacity without web stiffeners. The second number represents the Total Load capacity with stiffeners. (See Additional Notes below.)
3. Compare the design live load to the appropriate Live Load column.
4. Select a product that exceeds both the design total and live loads.
5. Specify web stiffeners as dictated by the Total Load column.
6. Concentrated loads, where required, shall be evaluated by the designer.

EXAMPLE:

An I-Joist has the continuous clear spans of 20'-8" and 22'-6", supporting 50 psf Floor Load and 25 psf Dead Load, spaced 24" oc. Select the shallowest joist that satisfies an L/600 live load deflection limit.

1. Select the row corresponding to a 23' span (longest of the spans).
2. Design Total Load = $(50 + 25) * (24 / 12) = 150$ plf
Design Live Load = $50 * (24 / 12) = 100$ plf
3. Select the first joist to exceed both Total Load and L/600:

Cannot use the LPI 36 series – exceeds Total Load for all depths at 23'

Span (ft)	11-7/8" LPI 36				14" LPI 36				16" LPI 36				Span (ft)
	Live Load			Total Load	Live Load			Total Load	Live Load			Total Load	
	L/600	L/480	L/360		L/600	L/480	L/360		L/600	L/480	L/360		
12'				162 / 202*				162 / 208*				162 / 208*	12'
13'	173			150 / 186*				150 / 192*				150 / 192*	13'
14'	143			139 / 173*				139 / 179*				139 / 179*	14'
15'	119	149		130 / 162*				130 / 167*				130 / 167*	15'
16'	100	126		122 / 152*	141			122 / 157*				122 / 157*	16'
17'	85	107	142	115 / 143*	120			115 / 147*				115 / 147*	17'
18'	73	91	122	109 / 135*	103	129		109 / 139*	135			109 / 139*	18'
19'	63	79	105	103 / 128*	89	111		103 / 132*	117			103 / 132*	19'
20'	54	68	91	98 / 122*	77	97		98 / 126*	102			98 / 126*	20'
21'	47	59	79	93 / 114*	68	85	113	93 / 120*	89	112		93 / 120*	21'
22'	42	52	70	89 / 104	59	74	99	89 / 114*	78	98		89 / 114*	22'
23'	37	46	61	85 / 92	52	66	88	85 / 109*	69	87		85 / 109*	23'
24'	32	41	54	82	46	58	78	82 / 105*	62	77	103	82 / 105*	24'
25'	29	36	48	73	41	52	69	79 / 97*	55	69	92	79 / 101*	25'
26'	-	-	-	-	37	46	62	76 / 90*	49	62	82	76 / 97*	26'
27'	-	-	-	-	33	42	56	73 / 83	44	55	74	73 / 93*	27'
28'	-	-	-	-	30	37	50	70 / 75	40	50	67	70 / 90*	28'
29'	-	-	-	-	27	34	45	68	36	45	60	68 / 84*	29'
30'	-	-	-	-	24	31	41	62	33	41	55	66 / 78*	30'
31'	-	-	-	-	-	-	-	-	30	37	50	63 / 73	31'
32'	-	-	-	-	-	-	-	-	27	34	45	61 / 68	32'
33'	-	-	-	-	-	-	-	-	25	31	42	60 / 63	33'
34'	-	-	-	-	-	-	-	-	23	28	38	57	34'
35'	-	-	-	-	-	-	-	-	-	-	-	-	35'
36'	-	-	-	-	-	-	-	-	-	-	-	-	36'
37'	-	-	-	-	-	-	-	-	-	-	-	-	37'
38'	-	-	-	-	-	-	-	-	-	-	-	-	38'

Span (ft)	18" LPI 36			Total Load	Span (ft)
	L/600	L/480	L/360		
12'				161 / 207	12'
13'				149 / 191	13'
14'				139 / 178	14'
15'				130 / 166	15'
16'				122 / 156	16'
17'				115 / 147	17'
18'				108 / 139	18'
19'				103 / 132	19'
20'				98 / 125	20'
21'	113			93 / 119	21'
22'	100			89 / 114	22'
23'	88			85 / 109	23'
24'	78	98		82 / 105	24'
25'	70	88		78 / 100	25'
26'	63	79		75 / 97	26'
27'	56	71		73 / 93	27'
28'	51	64	85	70 / 90	28'
29'	46	58	77	68 / 87	29'
30'	42	52	70	65 / 84	30'
31'	38	48	64	63 / 81	31'
32'	35	44	58	61 / 77	32'
33'	32	40	53	59 / 73	33'
34'	29	37	49	58 / 69	34'
35'	27	34	45	56 / 65	35'
36'	25	31	41	55 / 61	36'
37'	23	29	38	53 / 58	37'
38'	21	26	35	52 / 53	38'

DESIGN ASSUMPTIONS:

1. Span is the clear distance between supports for continuous span applications only. Continuous spans are based on the longest span. The shortest span shall not be less than 50% of the longest span.
2. The values in the tables are for uniform loads only. Concentrated loads, where required, shall be evaluated by the designer.
3. Total Load is for normal (100%) duration.
4. These tables do not reflect any additional stiffness provided by the floor sheathing.
5. Live Load deflection is limited to L/360, L/480 or L/600 as noted in the table.
6. Total Load deflection is limited to L/240. Long term deflection (creep) has not been considered.
7. These tables assume full lateral support of the compression flange (maximum unbraced length of 24").
8. The spans are based on an end bearing length of at least 1-3/4" for depths up to 16" and at least 2-1/2" for depths greater than 16", an intermediate bearing length of at least 3-1/2" and are limited to the bearing capacity for an SPF wall plate ($F_{CL} = 425$ psi).

ADDITIONAL NOTES:

1. The allowable loads represent the capacity of the joist in pounds per lineal foot (plf) of length.
2. The designer shall check both the Total Load and the appropriate Live Load column.
3. To design a double I-Joist, the values in these tables can be doubled, or the design loads on the I-Joist may be halved to verify the capacity of each ply. The capacity is additive. See Double I-Joist Connection detail on page 15.
4. Web stiffeners are not required where only one value is shown for Total Load or when the design total load does not exceed the first value (capacity without stiffeners) in the Total Load column where two values are given. Web stiffeners are required at interior supports if the design total load exceeds the first value. Do not exceed the second value (capacity with stiffeners). If the capacity with stiffeners is marked "**", then web stiffeners are also required at both end supports.
5. Web fillers are required for I-Joists seated in hangers that do not laterally support the top flange or for hangers that require nailing into the web.
6. Where the Live Load is blank, the Total Load governs the design.
7. Do not use a product where designated "-" without further analysis by a design professional.

Uniform Floor Load (PLF) Tables: LPI 42Plus Simple Spans

TO USE:

1. Select the span required.
2. Compare the design total load to the Total Load column. Where two numbers are shown, the first number represents the Total Load capacity without web stiffeners. The second number represents the Total Load capacity with stiffeners. (See Additional Notes below.)
3. Compare the design live load to the appropriate Live Load column.
4. Select a product that exceeds both the design total and live loads.
5. Specify web stiffeners as dictated by the Total Load column.
6. Concentrated loads, where required, shall be evaluated by the designer.

EXAMPLE:

An I-Joist has the simple clear span of 22'-6", supporting 50 psf Floor Load and 25 psf Dead Load, spaced 24" oc. Select the shallowest joist that satisfies an L/600 live load deflection limit.

1. Select the row corresponding to a 23' span.
2. Design Total Load = $(50 + 25) * (24 / 12) = 150$ plf
Design Live Load = $50 * (24 / 12) = 100$ plf
3. Select the first joist to exceed both Total Load and L/600:

The 20" LPI 42Plus supports 180 plf Total Load and 106 plf Live Load at L/600

NOTE: Web stiffeners required at both end supports.

Span (ft)	11-7/8" LPI 42Plus				14" LPI 42Plus				16" LPI 42Plus				Span (ft)
	Live Load			Total Load	Live Load			Total Load	Live Load			Total Load	
	L/600	L/480	L/360		L/600	L/480	L/360		L/600	L/480	L/360		
12'	205			208 / 247				216 / 273				223 / 298	12'
13'	168	210		192 / 229	234			200 / 253				206 / 275	13'
14'	138	173		179 / 212	194			186 / 235				192 / 256	14'
15'	116	145	193	167 / 199	163	204		173 / 219	214			179 / 239	15'
16'	97	122	163	157 / 186	138	172		163 / 206	181			168 / 224	16'
17'	83	103	138	148 / 176	117	147		153 / 194	155	194		159 / 211	17'
18'	71	88	118	139 / 166	101	126	168	145 / 183	133	167		150 / 200	18'
19'	61	76	102	132 / 152	87	109	145	137 / 174	116	145		142 / 189	19'
20'	53	66	88	126 / 133	76	95	126	131 / 165	101	126	168	135 / 180	20'
21'	46	58	77	116	66	83	111	124 / 150	88	110	147	129 / 172	21'
22'	40	51	68	102	58	73	97	119 / 136	78	97	130	123 / 158	22'
23'	36	45	60	90	51	64	86	114 / 125	69	86	115	118 / 145	23'
24'	31	39	53	79	46	57	76	109 / 115	61	76	102	113 / 133	24'
25'	28	35	47	71	41	51	68	102	54	68	91	108 / 123	25'
26'	25	31	42	63	36	45	61	91	49	61	82	104 / 113	26'
27'	22	28	38	57	33	41	55	82	44	55	73	100 / 105	27'
28'	20	25	34	51	29	37	49	74	39	49	66	97 / 98	28'
29'	18	23	31	46	26	33	44	67	36	45	60	90	29'
30'	-	-	-	-	24	30	40	61	32	41	54	82	30'
31'	-	-	-	-	22	27	37	55	29	37	49	74	31'
32'	-	-	-	-	20	25	33	50	27	34	45	68	32'
33'	-	-	-	-	18	23	30	46	25	31	41	62	33'
34'	-	-	-	-	17	21	28	42	22	28	38	57	34'
35'	-	-	-	-	-	-	-	-	21	26	35	52	35'
36'	-	-	-	-	-	-	-	-	19	24	32	48	36'
37'	-	-	-	-	-	-	-	-	18	22	30	45	37'
38'	-	-	-	-	-	-	-	-	16	20	27	41	38'

Span (ft)	18" LPI 42Plus				20" LPI 42Plus				24" LPI 42Plus				Span (ft)
	Live Load			Total Load	Live Load			Total Load	Live Load			Total Load	
	L/600	L/480	L/360		L/600	L/480	L/360		L/600	L/480	L/360		
12'				241 / 371				241 / 394				241 / 435	12'
13'				223 / 343				223 / 365				223 / 403	13'
14'	316			208 / 319				208 / 339				208 / 375	14'
15'	265			194 / 299				194 / 317				194 / 350	15'
16'	225			182 / 280	277			182 / 298				182 / 329	16'
17'	192	240		172 / 264	237			172 / 281				172 / 310	17'
18'	165	206		162 / 250	205	256		162 / 266				162 / 293	18'
19'	143	179		154 / 237	177	222		154 / 252	256			154 / 278	19'
20'	124	155	207	146 / 215	155	193		146 / 238	224			146 / 264	20'
21'	109	136	182	140 / 195	136	170		140 / 216	197	246		140 / 252	21'
22'	96	120	160	133 / 178	119	149		133 / 197	174	218		133 / 234	22'
23'	85	106	141	128 / 163	106	132	176	128 / 180	154	193		128 / 215	23'
24'	75	94	125	122 / 150	94	118	157	122 / 166	138	172		122 / 197	24'
25'	67	84	112	118 / 138	84	105	140	118 / 153	123	154		118 / 182	25'
26'	60	75	100	113 / 128	75	94	126	113 / 141	110	138		113 / 168	26'
27'	54	67	90	109 / 118	68	85	113	109 / 131	99	124		109 / 156	27'
28'	48	61	81	105 / 110	61	76	102	105 / 122	90	112		105 / 145	28'
29'	44	55	73	101 / 103	55	69	92	101 / 114	81	102		101 / 135	29'
30'	40	50	67	96	50	63	84	98 / 106	74	93	124	98 / 126	30'
31'	36	45	61	90	46	57	76	95 / 99	67	84	113	95 / 118	31'
32'	33	41	55	83	42	52	70	92 / 93	62	77	103	92 / 111	32'
33'	30	38	51	76	38	48	64	88	56	71	94	89 / 105	33'
34'	28	35	46	70	35	44	58	83	52	65	87	87 / 98	34'
35'	25	32	43	64	32	40	54	78	48	60	80	84 / 93	35'
36'	23	29	39	59	29	37	49	74	44	55	74	82 / 88	36'
37'	22	27	36	55	27	34	46	69	41	51	68	80 / 83	37'
38'	20	25	33	50	25	32	42	64	38	47	63	78 / 79	38'

DESIGN ASSUMPTIONS:

1. Span is the clear distance between supports for simple span applications only.
2. The values in the tables are for uniform loads only. Concentrated loads, where required, shall be evaluated by the designer.
3. Total Load is for normal (100%) duration.
4. These tables do not reflect any additional stiffness provided by the floor sheathing.
5. Live Load deflection is limited to L/360, L/480 or L/600 as noted in the table.
6. Total Load deflection is limited to L/240. Long term deflection (creep) has not been considered.
7. These tables assume full lateral support of the compression flange (maximum unbraced length of 24").
8. The spans are based on an end bearing length of at least 1-3/4" for depths up to 16" and at least 2-1/2" for depths greater than 16"; and are limited to the bearing capacity for an SPF wall plate ($F_{cL} = 425$ psi).

ADDITIONAL NOTES:

1. The allowable loads represent the capacity of the joist in pounds per lineal foot (plf) of length.
2. The designer shall check both the Total Load and the appropriate Live Load column.
3. To design a double I-Joist, the values in these tables can be doubled, or the design loads on the I-Joist may be halved to verify the capacity of each ply. The capacity is additive. See Double I-Joist Connection detail on page 15.
4. Web stiffeners are not required where only one value is shown for Total Load or when the design total load does not exceed the first value (capacity without stiffeners) in the Total Load column where two values are given. Web stiffeners are required at both end supports if the design total load exceeds the first value. Do not exceed the second value (capacity with stiffeners).
5. Web fillers are required for I-Joists seated in hangers that do not laterally support the top flange or for hangers that require nailing into the web.
6. Where the Live Load is blank, the Total Load governs the design.
7. Do not use a product where designated "-" without further analysis by a design professional.

Uniform Floor Load (PLF) Tables: LPI 42Plus Continuous Spans

TO USE:

1. Select the span required.
2. Compare the design total load to the Total Load column. Where two numbers are shown, the first number represents the Total Load capacity without web stiffeners. The second number represents the Total Load capacity with stiffeners. (See Additional Notes below.)
3. Compare the design live load to the appropriate Live Load column.
4. Select a product that exceeds both the design total and live loads.
5. Specify web stiffeners as dictated by the Total Load column.
6. Concentrated loads, where required, shall be evaluated by the designer.

EXAMPLE:

An I-Joist has the simple clear span of 22'-6", supporting 50 psf Floor Load and 25 psf Dead Load, spaced 24" oc. Select the shallowest joist that satisfies an L/600 live load deflection limit.

1. Select the row corresponding to a 23' span.
2. Design Total Load = $(50 + 25) * (24 / 12) = 150$ plf
Design Live Load = $50 * (24 / 12) = 100$ plf
3. Select the first joist to exceed both Total Load and L/600:

The 20" LPI 42Plus supports 151 plf Total Load and 137 plf Live Load at L/600

NOTE: Web stiffeners required at the intermediate support and at both end supports.

Span (ft)	11-7/8" LPI 42Plus				14" LPI 42Plus				16" LPI 42Plus				Span (ft)
	Live Load			Total Load	Live Load			Total Load	Live Load			Total Load	
	L/600	L/480	L/360		L/600	L/480	L/360		L/600	L/480	L/360		
12'				196 / 212				204 / 232				211 / 245	12'
13'				182 / 196				188 / 214				195 / 227	13'
14'	178			169 / 182				175 / 199				181 / 211	14'
15'	149			158 / 170				164 / 186				169 / 197	15'
16'	125	157		148 / 160				154 / 175				159 / 185	16'
17'	107	133		139 / 150	151			145 / 164				150 / 174	17'
18'	91	114		132 / 142	130			137 / 155				141 / 165	18'
19'	79	99	132	125 / 135	112	141		130 / 147	149			134 / 156	19'
20'	68	86	114	119 / 128	98	122		123 / 140	130			127 / 148	20'
21'	60	75	100	113 / 122	86	107		117 / 133	114			121 / 141	21'
22'	52	66	88	108 / 112	75	94	126	112 / 127	101	126		116 / 135	22'
23'	46	58	77	103	67	83	111	107 / 122	89	111		111 / 129	23'
24'	41	51	69	94	59	74	99	103 / 114	79	99		106 / 124	24'
25'	36	46	61	87	53	66	88	99 / 105	71	89	118	102 / 119	25'
26'	33	41	55	81	47	59	79	95 / 97	63	79	106	98 / 113	26'
27'	29	37	49	74	42	53	71	90	57	71	95	95 / 105	27'
28'	26	33	44	66	38	48	64	84	51	64	86	91 / 97	28'
29'	24	30	40	60	35	43	58	78	47	58	78	88 / 91	29'
30'	-	-	-	-	31	39	52	73	42	53	71	85	30'
31'	-	-	-	-	28	36	48	68	38	48	64	79	31'
32'	-	-	-	-	26	33	44	64	35	44	59	74	32'
33'	-	-	-	-	24	30	40	60	32	40	54	70	33'
34'	-	-	-	-	22	27	37	55	29	37	49	66	34'
35'	-	-	-	-	-	-	-	-	27	34	45	62	35'
36'	-	-	-	-	-	-	-	-	25	31	42	59	36'
37'	-	-	-	-	-	-	-	-	23	29	39	56	37'
38'	-	-	-	-	-	-	-	-	21	27	36	53	38'

Span (ft)	18" LPI 42Plus				20" LPI 42Plus				24" LPI 42Plus				Span (ft)
	Live Load			Total Load	Live Load			Total Load	Live Load			Total Load	
	L/600	L/480	L/360		L/600	L/480	L/360		L/600	L/480	L/360		
12'				223 / 277*				223 / 285*				223 / 300*	12'
13'				206 / 256*				206 / 264*				206 / 277*	13'
14'				192 / 238*				192 / 245*				192 / 258*	14'
15'				179 / 223*				179 / 229*				179 / 241*	15'
16'				168 / 209*				168 / 215*				168 / 226*	16'
17'				159 / 197*				159 / 203*				159 / 213*	17'
18'				150 / 186*				150 / 192*				150 / 202*	18'
19'				142 / 177*				142 / 182*				142 / 191*	19'
20'	161			135 / 168*				135 / 173*				135 / 182*	20'
21'	141			129 / 160*				129 / 165*				129 / 173*	21'
22'	124			123 / 153*	155			123 / 157*				123 / 166*	22'
23'	110	138		118 / 146*	137			118 / 151*				118 / 158*	23'
24'	98	122		113 / 140*	122			113 / 144*				113 / 152*	24'
25'	87	109		108 / 135*	109	137		108 / 139*				108 / 146*	25'
26'	78	98		104 / 127*	98	123		104 / 133*				104 / 140*	26'
27'	70	88	117	100 / 118	88	110		100 / 128*	129			100 / 135*	27'
28'	63	79	106	97 / 110	80	100		97 / 121*	117			97 / 130*	28'
29'	57	72	96	94 / 102	72	90		94 / 113*	106			94 / 126*	29'
30'	52	65	87	90 / 96	65	82		90 / 106	97	121		90 / 122*	30'
31'	47	59	79	88 / 90	60	75		88 / 99	88	110		88 / 118*	31'
32'	43	54	72	84	54	68	91	85 / 93	81	101		85 / 111*	32'
33'	40	50	66	79	50	62	83	82 / 88	74	92		82 / 104*	33'
34'	36	45	61	75	46	57	76	80 / 82	68	85		80 / 98*	34'
35'	33	42	56	70	42	53	70	78	62	78		78 / 93	35'
36'	31	38	51	66	39	48	65	74	58	72		75 / 88	36'
37'	28	35	47	63	36	45	60	70	53	67		73 / 83	37'
38'	26	33	44	60	33	41	55	66	49	62		71 / 79	38'

DESIGN ASSUMPTIONS:

1. Span is the clear distance between supports for continuous span applications only. Continuous spans are based on the longest span. The shortest span shall not be less than 50% of the longest span.
2. The values in the tables are for uniform loads only. Concentrated loads, where required, shall be evaluated by the designer.
3. Total Load is for normal (100%) duration.
4. These tables do not reflect any additional stiffness provided by the floor sheathing.
5. Live Load deflection is limited to L/360, L/480 or L/600 as noted in the table.
6. Total Load deflection is limited to L/240. Long term deflection (creep) has not been considered.
7. These tables assume full lateral support of the compression flange (maximum unbraced length of 24").
8. The spans are based on an end bearing length of at least 1-3/4" for depths up to 16" and at least 2-1/2" for depths greater than 16", an intermediate bearing length of at least 3-1/2" and are limited to the bearing capacity for an SPF wall plate ($F_{CL} = 425$ psi).

ADDITIONAL NOTES:

1. The allowable loads represent the capacity of the joist in pounds per lineal foot (plf) of length.
2. The designer shall check both the Total Load and the appropriate Live Load column.
3. To design a double I-Joist, the values in these tables can be doubled, or the design loads on the I-Joist may be halved to verify the capacity of each ply. The capacity is additive. See Double I-Joist Connection detail on page 15.
4. Web stiffeners are not required where only one value is shown for Total Load or when the design total load does not exceed the first value (capacity without stiffeners) in the Total Load column where two values are given. Web stiffeners are required at interior supports if the design total load exceeds the first value. Do not exceed the second value (capacity with stiffeners). If the capacity with stiffeners is marked "*", then web stiffeners are also required at both end supports.
5. Web fillers are required for I-Joists seated in hangers that do not laterally support the top flange or for hangers that require nailing into the web.
6. Where the Live Load is blank, the Total Load governs the design.
7. Do not use a product where designated "-" without further analysis by a design professional.

Uniform Floor Load (PLF) Tables: LPI 52Plus Simple Spans

TO USE:

1. Select the span required.
2. Compare the design total load to the Total Load column. Where two numbers are shown, the first number represents the Total Load capacity without web stiffeners. The second number represents the Total Load capacity with stiffeners. (See Additional Notes below.)
3. Compare the design live load to the appropriate Live Load column.
4. Select a product that exceeds both the design total and live loads.
5. Specify web stiffeners as dictated by the Total Load column.
6. Concentrated loads, where required, shall be evaluated by the designer.

EXAMPLE:

An I-Joist has the simple clear span of 19'-6", supporting 50 psf Floor Load and 25 psf Dead Load, spaced 24" oc. Select the shallowest joist that satisfies an L/600 live load deflection limit.

1. Select the row corresponding to a 20' span.
2. Design Total Load = $(50 + 25) * (24 / 12) = 150$ plf
Design Live Load = $50 * (24 / 12) = 100$ plf
3. Select the first joist to exceed both Total Load and L/600:

The 16" LPI 52Plus supports 212 plf Total Load and 111 plf Live Load at L/600

NOTE: Web stiffeners required at both end supports.

Span (ft)	11-7/8" LPI 52Plus				14" LPI 52Plus				16" LPI 52Plus				Span (ft)
	Live Load			Total Load	Live Load			Total Load	Live Load			Total Load	
	L/600	L/480	L/360		L/600	L/480	L/360		L/600	L/480	L/360		
12'	231	289		228 / 300				232 / 326				237 / 351	12'
13'	188	235		210 / 277	262			215 / 301				219 / 324	13'
14'	155	194		196 / 258	217	272		200 / 280	284			204 / 301	14'
15'	129	162	216	183 / 241	182	227		187 / 262	238			190 / 282	15'
16'	109	136	181	172 / 226	153	192		175 / 246	202	252		179 / 264	16'
17'	92	115	154	162 / 213	130	163	218	165 / 232	172	215		168 / 249	17'
18'	79	98	131	153 / 197	112	140	187	156 / 219	148	185		159 / 235	18'
19'	68	85	113	145 / 170	96	121	161	148 / 207	128	160	213	151 / 223	19'
20'	59	73	98	138 / 147	84	105	140	141 / 197	111	139	186	143 / 212	20'
21'	51	64	85	128	73	92	122	134 / 182	97	122	162	137 / 202	21'
22'	45	56	75	113	64	80	107	128 / 161	86	107	143	130 / 193	22'
23'	39	49	66	99	57	71	95	122 / 142	76	95	126	125 / 176	23'
24'	35	44	58	88	50	63	84	117 / 126	67	84	112	120 / 162	24'
25'	31	39	52	78	45	56	75	112	60	75	100	115 / 149	25'
26'	28	35	46	70	40	50	67	100	53	67	89	110 / 134	26'
27'	25	31	42	63	36	45	60	90	48	60	80	106 / 121	27'
28'	22	28	37	56	32	40	54	81	43	54	72	103 / 109	28'
29'	20	25	34	51	29	36	49	73	39	49	65	98	29'
30'	-	-	-	-	26	33	44	67	35	44	59	89	30'
31'	-	-	-	-	24	30	40	61	32	40	54	81	31'
32'	-	-	-	-	22	27	37	55	29	37	49	74	32'
33'	-	-	-	-	20	25	33	50	27	34	45	68	33'
34'	-	-	-	-	18	23	31	46	25	31	41	62	34'
35'	-	-	-	-	-	-	-	-	23	28	38	57	35'
36'	-	-	-	-	-	-	-	-	21	26	35	53	36'
37'	-	-	-	-	-	-	-	-	19	24	32	49	37'
38'	-	-	-	-	-	-	-	-	18	22	30	45	38'

DESIGN ASSUMPTIONS:

1. Span is the clear distance between supports for simple span applications only.
2. The values in the tables are for uniform loads only. Concentrated loads, where required, shall be evaluated by the designer.
3. Total Load is for normal (100%) duration.
4. These tables do not reflect any additional stiffness provided by the floor sheathing.
5. Live Load deflection is limited to L/360, L/480 or L/600 as noted in the table.
6. Total Load deflection is limited to L/240. Long term deflection (creep) has not been considered.
7. These tables assume full lateral support of the compression flange (maximum unbraced length of 24").
8. The spans are based on an end bearing length of at least 1-3/4" for depths up to 16" and at least 2-1/2" for depths greater than 16", and are limited to the bearing capacity for an SPF wall plate ($F_{cL} = 425$ psi).

ADDITIONAL NOTES:

1. The allowable loads represent the capacity of the joist in pounds per lineal foot (plf) of length.
2. The designer shall check both the Total Load and the appropriate Live Load column.
3. To design a double I-Joist, the values in these tables can be doubled, or the design loads on the I-Joist may be halved to verify the capacity of each ply. The capacity is additive. See Double I-Joist Connection detail on page 15.
4. Web stiffeners are not required where only one value is shown for Total Load or when the design total load does not exceed the first value (capacity without stiffeners) in the Total Load column where two values are given. Web stiffeners are required at both end supports if the design total load exceeds the first value. Do not exceed the second value (capacity with stiffeners).
5. Web fillers are required for I-Joists seated in hangers that do not laterally support the top flange or for hangers that require nailing into the web.
6. Where the Live Load is blank, the Total Load governs the design.
7. Do not use a product where designated "-" without further analysis by a design professional.

Uniform Floor Load (PLF) Tables: LPI 52Plus Continuous Spans

TO USE:

1. Select the span required.
2. Compare the design total load to the Total Load column. Where two numbers are shown, the first number represents the Total Load capacity without web stiffeners. The second number represents the Total Load capacity with stiffeners. (See Additional Notes below.)
3. Compare the design live load to the appropriate Live Load column.
4. Select a product that exceeds both the design total and live loads.
5. Specify web stiffeners as dictated by the Total Load column.
6. Concentrated loads, where required, shall be evaluated by the designer.

EXAMPLE:

An I-Joist has the simple clear span of 19'-6", supporting 50 psf Floor Load and 25 psf Dead Load, spaced 24" oc. Select the shallowest joist that satisfies an L/600 live load deflection limit.

1. Select the row corresponding to a 20' span.
2. Design Total Load = $(50 + 25) * (24 / 12) = 150$ plf
Design Live Load = $50 * (24 / 12) = 100$ plf
3. Select the first joist to exceed both Total Load and L/600:

The 14" LPI 52Plus supports 167 plf Total Load and 108 plf Live Load at L/600

NOTE: Web stiffeners required at the intermediate support and at both end supports.

Span (ft)	11-7/8" LPI 52Plus				14" LPI 52Plus				16" LPI 52Plus				Span (ft)
	Live Load			Total Load	Live Load			Total Load	Live Load			Total Load	
	L/600	L/480	L/360		L/600	L/480	L/360		L/600	L/480	L/360		
12'				222 / 260*				223 / 277*				224 / 293*	12'
13'				205 / 240*				206 / 256*				207 / 271*	13'
14'	199			191 / 223*				192 / 238*				193 / 252*	14'
15'	166	208		178 / 209*				179 / 222*				180 / 235*	15'
16'	140	175		167 / 196*	197			168 / 209*				169 / 221*	16'
17'	119	149		158 / 185*	168			158 / 197*				159 / 208*	17'
18'	102	127	170	149 / 174*	144	180		150 / 186*	190			150 / 197*	18'
19'	88	110	146	141 / 165*	125	156		142 / 176*	165			143 / 186*	19'
20'	76	95	127	134 / 157*	108	136		135 / 167*	144			136 / 177*	20'
21'	66	83	111	128 / 150*	95	119	158	129 / 160*	126	157		129 / 169*	21'
22'	58	73	97	122 / 137	83	104	139	123 / 152*	111	139		123 / 161*	22'
23'	51	64	86	117 / 125	74	92	123	117 / 146*	98	123		118 / 154*	23'
24'	45	57	76	112 / 114	65	82	109	113 / 139*	87	109	145	113 / 148*	24'
25'	40	51	68	102	58	73	97	108 / 128*	78	97	130	109 / 142*	25'
26'	36	45	60	91	52	65	87	104 / 118	70	87	116	104 / 137*	26'
27'	32	40	54	81	47	58	78	100 / 110	62	78	104	101 / 127*	27'
28'	29	36	49	73	42	53	70	97 / 102	56	71	94	97 / 118*	28'
29'	26	33	44	66	38	48	64	93 / 95	51	64	85	94 / 110*	29'
30'	-	-	-	-	34	43	58	87	46	58	77	91 / 103	30'
31'	-	-	-	-	31	39	52	79	42	53	70	88 / 97	31'
32'	-	-	-	-	29	36	48	72	38	48	64	85 / 91	32'
33'	-	-	-	-	26	33	44	66	35	44	59	82 / 85	33'
34'	-	-	-	-	24	30	40	60	32	40	54	80	34'
35'	-	-	-	-	-	-	-	-	30	37	50	75	35'
36'	-	-	-	-	-	-	-	-	27	34	46	69	36'
37'	-	-	-	-	-	-	-	-	25	32	42	64	37'
38'	-	-	-	-	-	-	-	-	23	29	39	59	38'

DESIGN ASSUMPTIONS:

1. Span is the clear distance between supports for continuous span applications only. Continuous spans are based on the longest span. The shortest span shall not be less than 50% of the longest span.
2. The values in the tables are for uniform loads only. Concentrated loads, where required, shall be evaluated by the designer.
3. Total Load is for normal (100%) duration.
4. These tables do not reflect any additional stiffness provided by the floor sheathing.
5. Live Load deflection is limited to L/360, L/480 or L/600 as noted in the table.
6. Total Load deflection is limited to L/240. Long term deflection (creep) has not been considered.
7. These tables assume full lateral support of the compression flange (maximum unbraced length of 24").
8. The spans are based on an end bearing length of at least 1-3/4" for depths up to 16" and at least 2-1/2" for depths greater than 16", an intermediate bearing length of at least 3-1/2" and are limited to the bearing capacity for an SPF wall plate ($F_{CL} = 425$ psi).

ADDITIONAL NOTES:

1. The allowable loads represent the capacity of the joist in pounds per lineal foot (plf) of length.
2. The designer shall check both the Total Load and the appropriate Live Load column.
3. To design a double I-Joist, the values in these tables can be doubled, or the design loads on the I-Joist may be halved to verify the capacity of each ply. The capacity is additive. See Double I-Joist Connection detail on page 15.
4. Web stiffeners are not required where only one value is shown for Total Load or when the design total load does not exceed the first value (capacity without stiffeners) in the Total Load column where two values are given. Web stiffeners are required at interior supports if the design total load exceeds the first value. Do not exceed the second value (capacity with stiffeners). If the capacity with stiffeners is marked ***, then web stiffeners are also required at both end supports.
5. Web fillers are required for I-Joists seated in hangers that do not laterally support the top flange or for hangers that require nailing into the web.
6. Where the Live Load is blank, the Total Load governs the design.
7. Do not use a product where designated "-" without further analysis by a design professional.

Uniform Floor Load (PLF) Tables: LPI 56 Simple Spans

TO USE:

1. Select the span required.
2. Compare the design total load to the Total Load column. Where two numbers are shown, the first number represents the Total Load capacity without web stiffeners. The second number represents the Total Load capacity with stiffeners. (See Additional Notes below.)
3. Compare the design live load to the appropriate Live Load column.
4. Select a product that exceeds both the design total and live loads.
5. Specify web stiffeners as dictated by the Total Load column.
6. Concentrated loads, where required, shall be evaluated by the designer.

EXAMPLE:

An I-Joist has the simple clear span of 22'-6", supporting 50 psf Floor Load and 25 psf Dead Load, spaced 24" oc. Select the shallowest joist that satisfies an L/600 live load deflection limit.

1. Select the row corresponding to a 23' span.
2. Design Total Load = $(50 + 25) * (24 / 12) = 150$ plf
Design Live Load = $50 * (24 / 12) = 100$ plf
3. Select the first joist to exceed both Total Load and L/600:

The 18" LPI 56 supports 196 plf Total Load and 102 plf Live Load at L/600

NOTE: Web stiffeners required at both end supports.

Span (ft)	11-7/8" LPI 56				14" LPI 56				16" LPI 56				Span (ft)
	Live Load			Total Load	Live Load			Total Load	Live Load			Total Load	
	L/600	L/480	L/360		L/600	L/480	L/360		L/600	L/480	L/360		
12'	242			192 / 276				192 / 294				192 / 312	12'
13'	199	248		177 / 255				178 / 272				178 / 288	13'
14'	165	206		165 / 237	227			165 / 253				165 / 268	14'
15'	138	172		154 / 222	191			154 / 237	247			155 / 250	15'
16'	116	146	194	145 / 208	162	203		145 / 222	210			145 / 235	16'
17'	99	124	165	136 / 196	138	173		136 / 209	180			137 / 221	17'
18'	85	106	142	129 / 185	119	149		129 / 198	155	194		129 / 209	18'
19'	73	92	122	122 / 176	103	129	172	122 / 187	135	169		122 / 198	19'
20'	64	80	106	116 / 160	90	112	150	116 / 178	118	147		116 / 189	20'
21'	56	70	93	111 / 140	79	98	131	111 / 170	103	129		111 / 180	21'
22'	49	61	82	106 / 123	69	87	116	106 / 162	91	114	152	106 / 172	22'
23'	43	54	72	101 / 108	61	77	102	101 / 154	81	101	135	101 / 164	23'
24'	38	48	64	96	54	68	91	97 / 137	72	90	120	97 / 157	24'
25'	34	43	57	86	48	61	81	93 / 122	64	80	107	93 / 151	25'
26'	30	38	51	76	43	54	73	90 / 109	57	72	96	90 / 144	26'
27'	27	34	46	69	39	49	65	86 / 98	52	65	86	86 / 130	27'
28'	24	31	41	62	35	44	59	83 / 88	47	58	78	83 / 117	28'
29'	22	28	37	56	32	40	53	80	42	53	71	80 / 106	29'
30'	-	-	-	-	29	36	48	73	38	48	64	78 / 97	30'
31'	-	-	-	-	26	33	44	66	35	44	58	75 / 88	31'
32'	-	-	-	-	24	30	40	60	32	40	53	73 / 80	32'
33'	-	-	-	-	22	27	37	55	29	37	49	71 / 74	33'
34'	-	-	-	-	20	25	34	51	27	33	45	67	34'
35'	-	-	-	-	-	-	-	-	25	31	41	62	35'
36'	-	-	-	-	-	-	-	-	23	28	38	57	36'
37'	-	-	-	-	-	-	-	-	21	26	35	53	37'
38'	-	-	-	-	-	-	-	-	19	24	32	49	38'

Span (ft)	18" LPI 56				24" LPI 56				Span (ft)
	Live Load			Total Load	Live Load			Total Load	
	L/600	L/480	L/360		L/600	L/480	L/360		
12'				211 / 370				215 / 446	12'
13'				196 / 342				199 / 412	13'
14'				182 / 319				185 / 384	14'
15'				170 / 298				173 / 359	15'
16'	260			160 / 280				163 / 337	16'
17'	224			151 / 264				153 / 318	17'
18'	194	242		142 / 249				145 / 300	18'
19'	169	211		135 / 236				138 / 285	19'
20'	148	185		128 / 225	256			131 / 271	20'
21'	130	162		122 / 214	226			125 / 258	21'
22'	115	144	192	117 / 205	201			119 / 247	22'
23'	102	127	170	112 / 196	179	224		114 / 236	23'
24'	91	114	152	107 / 188	160	200		109 / 226	24'
25'	81	102	136	103 / 180	144	180		105 / 217	25'
26'	73	91	122	99 / 174	130	162		101 / 209	26'
27'	66	82	110	95 / 165	117	146	195	97 / 202	27'
28'	59	74	99	92 / 149	106	133	177	94 / 194	28'
29'	54	67	90	89 / 135	96	121	161	91 / 188	29'
30'	49	61	82	86 / 123	88	110	147	88 / 182	30'
31'	45	56	75	83 / 112	80	100	134	85 / 175	31'
32'	41	51	68	81 / 102	74	92	123	82 / 164	32'
33'	37	47	62	78 / 94	67	84	113	80 / 154	33'
34'	34	43	57	76 / 86	62	78	104	77 / 145	34'
35'	31	39	53	74 / 79	57	72	96	75 / 137	35'
36'	29	36	49	72 / 73	53	66	88	73 / 130	36'
37'	27	34	45	68	49	61	82	71 / 123	37'
38'	25	31	42	63	45	57	76	69 / 114	38'

DESIGN ASSUMPTIONS:

1. Span is the clear distance between supports for simple span applications only.
2. The values in the tables are for uniform loads only. Concentrated loads, where required, shall be evaluated by the designer.
3. Total Load is for normal (100%) duration.
4. These tables do not reflect any additional stiffness provided by the floor sheathing.
5. Live Load deflection is limited to L/360, L/480 or L/600 as noted in the table.
6. Total Load deflection is limited to L/240. Long term deflection (creep) has not been considered.
7. These tables assume full lateral support of the compression flange (maximum unbraced length of 24").
8. The spans are based on an end bearing length of at least 1-3/4" for depths up to 16" and at least 2-1/2" for depths greater than 16", and are limited to the bearing capacity for an SPF wall plate ($F_{c\perp} = 425$ psi).

ADDITIONAL NOTES:

1. The allowable loads represent the capacity of the joist in pounds per lineal foot (plf) of length.
2. The designer shall check both the Total Load and the appropriate Live Load column.
3. To design a double I-Joist, the values in these tables can be doubled, or the design loads on the I-Joist may be halved to verify the capacity of each ply. The capacity is additive. See Double I-Joist Connection detail on page 15.
4. Web stiffeners are not required where only one value is shown for Total Load or when the design total load does not exceed the first value (capacity without stiffeners) in the Total Load column where two values are given. Web stiffeners are required at both end supports if the design total load exceeds the first value. Do not exceed the second value (capacity with stiffeners).
5. Web fillers are required for I-Joists seated in hangers that do not laterally support the top flange or for hangers that require nailing into the web.
6. Where the Live Load is blank, the Total Load governs the design.
7. Do not use a product where designated "-" without further analysis by a design professional.

Uniform Floor Load (PLF) Tables: LPI 56 Continuous Spans

TO USE:

- Select the span required.
- Compare the design total load to the Total Load column. Where two numbers are shown, the first number represents the Total Load capacity without web stiffeners. The second number represents the Total Load capacity with stiffeners. (See Additional Notes below.)
- Compare the design live load to the appropriate Live Load column.
- Select a product that exceeds both the design total and live loads.
- Specify web stiffeners as dictated by the Total Load column.
- Concentrated loads, where required, shall be evaluated by the designer.

EXAMPLE:

An I-Joist has the simple clear span of 22'-6", supporting 50 psf Floor Load and 25 psf Dead Load, spaced 24" oc. Select the shallowest joist that satisfies an L/600 live load deflection limit.

- Select the row corresponding to a 23' span.
- Design Total Load = $(50 + 25) * (24 / 12) = 150$ plf
Design Live Load = $50 * (24 / 12) = 100$ plf
- Select the first joist to exceed both Total Load and L/600:

The 18" LPI 56 supports 151 plf Total Load and 132 plf Live Load at L/600

NOTE: Web stiffeners required at the intermediate support and at both end supports.

Span (ft)	11-7/8" LPI 56				14" LPI 56				16" LPI 56				Span (ft)
	Live Load			Total Load	Live Load			Total Load	Live Load			Total Load	
	L/600	L/480	L/360		L/600	L/480	L/360		L/600	L/480	L/360		
12'				203 / 251*				203 / 263*				203 / 276*	12'
13'				188 / 232*				188 / 244*				188 / 255*	13'
14'	211			175 / 216*				175 / 226*				175 / 237*	14'
15'	177			163 / 201*				163 / 212*				163 / 222*	15'
16'	150	187		153 / 189*				153 / 199*				153 / 208*	16'
17'	128	160		144 / 178*	178			144 / 187*				144 / 196*	17'
18'	110	137		136 / 168*	153			136 / 177*				136 / 185*	18'
19'	95	118	158	129 / 160*	133	166		129 / 168*	174			129 / 176*	19'
20'	82	103	138	123 / 152*	116	145		123 / 159*	152			123 / 167*	20'
21'	72	90	120	117 / 145*	102	127		117 / 152*	134			117 / 159*	21'
22'	63	79	106	112 / 138*	90	112		112 / 145*	118	147		112 / 152*	22'
23'	56	70	93	107 / 132*	79	99	133	107 / 139*	105	131		107 / 145*	23'
24'	50	62	83	103 / 125*	71	88	118	103 / 133*	93	116		103 / 139*	24'
25'	44	55	74	99 / 111*	63	79	105	99 / 128*	83	104		99 / 134*	25'
26'	39	49	66	95 / 99*	56	71	94	95 / 123*	75	93	125	95 / 129*	26'
27'	35	44	59	89	51	63	85	91 / 118*	67	84	112	91 / 124*	27'
28'	32	40	54	81	46	57	77	88 / 114*	61	76	101	88 / 120*	28'
29'	29	36	48	73	41	52	69	85 / 104*	55	69	92	85 / 115*	29'
30'	-	-	-	-	38	47	63	82 / 95*	50	63	84	82 / 112*	30'
31'	-	-	-	-	34	43	57	80 / 86*	45	57	76	80 / 108*	31'
32'	-	-	-	-	31	39	52	77 / 79	42	52	70	77 / 105*	32'
33'	-	-	-	-	28	36	48	72	38	48	64	75 / 96*	33'
34'	-	-	-	-	26	33	44	66	35	44	59	73 / 88*	34'
35'	-	-	-	-	-	-	-	-	32	40	54	70 / 81*	35'
36'	-	-	-	-	-	-	-	-	30	37	50	68 / 75*	36'
37'	-	-	-	-	-	-	-	-	27	34	46	67 / 69	37'
38'	-	-	-	-	-	-	-	-	25	32	42	64	38'

Span (ft)	18" LPI 56				24" LPI 56				Span (ft)
	Live Load			Total Load	Live Load			Total Load	
	L/600	L/480	L/360		L/600	L/480	L/360		
12'				202 / 287*				202 / 323*	12'
13'				187 / 265*				187 / 299*	13'
14'				174 / 247*				174 / 278*	14'
15'				163 / 231*				163 / 260*	15'
16'				153 / 216*				153 / 244*	16'
17'				144 / 204*				144 / 230*	17'
18'				136 / 193*				136 / 217*	18'
19'				129 / 183*				129 / 206*	19'
20'				123 / 174*				123 / 196*	20'
21'				117 / 166*				117 / 187*	21'
22'	149			112 / 158*				112 / 178*	22'
23'	132			107 / 151*				107 / 171*	23'
24'	118			102 / 145*				102 / 164*	24'
25'	106	132		98 / 139*				98 / 157*	25'
26'	95	119		95 / 134*				95 / 151*	26'
27'	85	107		91 / 129*				91 / 146*	27'
28'	77	97		88 / 125*	138			88 / 141*	28'
29'	70	88	117	85 / 120*	125			85 / 136*	29'
30'	64	80	107	82 / 116*	114			82 / 131*	30'
31'	58	73	97	79 / 113*	105			79 / 127*	31'
32'	53	67	89	77 / 109*	96	120		77 / 123*	32'
33'	49	61	82	75 / 106*	88	110		75 / 119*	33'
34'	45	56	75	72 / 103*	81	101		72 / 116*	34'
35'	41	52	69	70 / 100*	75	93		70 / 113*	35'
36'	38	48	64	68 / 96*	69	86		68 / 110*	36'
37'	35	44	59	67 / 88*	64	80		67 / 107*	37'
38'	32	41	54	65 / 82*	59	74	99	65 / 104*	38'

DESIGN ASSUMPTIONS:

- Span is the clear distance between supports for continuous span applications only. Continuous spans are based on the longest span. The shortest span shall not be less than 50% of the longest span.
- The values in the tables are for uniform loads only. Concentrated loads, where required, shall be evaluated by the designer.
- Total Load is for normal (100%) duration.
- These tables do not reflect any additional stiffness provided by the floor sheathing.
- Live Load deflection is limited to L/360, L/480 or L/600 as noted in the table.
- Total Load deflection is limited to L/240. Long term deflection (creep) has not been considered.
- These tables assume full lateral support of the compression flange (maximum unbraced length of 24").
- The spans are based on an end bearing length of at least 1-3/4" for depths up to 16" and at least 2-1/2" for depths greater than 16", an intermediate bearing length of at least 3-1/2" and are limited to the bearing capacity for an SPF wall plate ($F_{CL} = 425$ psi).

ADDITIONAL NOTES:

- The allowable loads represent the capacity of the joist in pounds per lineal foot (plf) of length.
- The designer shall check both the Total Load and the appropriate Live Load column.
- To design a double I-Joist, the values in these tables can be doubled, or the design loads on the I-Joist may be halved to verify the capacity of each ply. The capacity is additive. See Double I-Joist Connection detail on page 15.
- Web stiffeners are not required where only one value is shown for Total Load or when the design total load does not exceed the first value (capacity without stiffeners) in the Total Load column where two values are given. Web stiffeners are required at interior supports if the design total load exceeds the first value. Do not exceed the second value (capacity with stiffeners). If the capacity with stiffeners is marked ***, then web stiffeners are also required at both end supports.
- Web fillers are required for I-Joists seated in hangers that do not laterally support the top flange or for hangers that require nailing into the web.
- Where the Live Load is blank, the Total Load governs the design.
- Do not use a product where designated "-" without further analysis by a design professional.

Floor Details

<p>A1 RIM BOARD</p> <p>Fasten rim board to each floor I-joist using one 8d nail or 10d box nail per flange</p> <p>Web stiffener for Detail A1W only Same depth as I-joist</p> <p>8d nails at 6" oc toe-nailed from outside of building</p>	<p>A2W RIM BOARD Web Stiffener Required</p> <p>A2 RIM JOIST</p> <p>Refer to Note 8</p> <p>Web stiffener for Detail A2W only</p> <p>Rim joists with flanges wider than 1-3/4" require a minimum 2 x 6 plate</p> <p>Fasten rim joist to each floor I-joist with one 10d nail into the end of each flange. Use 16d box nails for rim joists with flanges wider than 1-3/4".</p> <p>8d nails at 6" oc (when used for shear transfer, nail to bearing plate with same nailing schedule for decking)</p>	<p>A3 BLOCKING AT EXTERIOR WALL</p> <p>A3W BLOCKING AT EXTERIOR WALL Web Stiffener Required</p> <p>8d nails at 6" oc (when used for shear transfer, nail to bearing plate with same nailing schedule for decking)</p> <p>Web stiffener for Detail A3W only</p>
---	--	--

<p>A4 SOLID BLOCKING AT EXTERIOR WALL</p> <p>A4W SOLID BLOCKING AT EXTERIOR WALL Web Stiffener Required</p> <p>Web stiffener for Detail A4W only</p> <p>LP OSB Rim Board as blocking</p> <p>Same depth as I-joist</p> <p>8d nails at 6" oc toe-nailed from outside of building</p>	<p>A5 JOIST SUPPORT NAILING</p> <p>Secure I-joist to plate with two 8d nails or 10d box. Drive one nail from each side of I-joist, angled inward.</p> <p>Place nail 1-1/2" min. from end of I-joist. If nails are close to edge of plate, drive at an angle to reduce splitting</p>	<p>B1 WEB STIFFENERS AT INTERIOR SUPPORT (When Required)</p> <p>Verify stiffener requirements (see Web Stiffener detail)</p>
--	--	---

<p>B2 SQUASH BLOCKS</p> <p>Blocking panels may be required with shear wall</p> <p>Use double squash blocks as specified. Squash blocks shall be cut 1/16" taller than I-joist. 2 x 4 min.</p> <p>Stagger 8d or 10d nails to avoid splitting</p> <p>Bearing wall aligned under wall above</p> <p>Toe-nail 8d or 10d box nail to plate</p>	<p>B3 BLOCKING AT INTERIOR SUPPORT</p> <p>Blocking is not required if no wall above unless I-joists end at support. Blocking may be required at interior supports by project designer or by code for seismic design</p> <p>Bearing wall aligned under wall above</p> <p>LP Rim Board or LP LVL may be substituted for the LPI blocking</p>	<p>NON-STACKING WALLS</p> <p>LP SolidStart I-joists shall be designed to carry all applied loads including walls from above that do not stack directly over the I-joist support.</p>
---	---	---

<p>D2 POST LOADS</p> <p>Squash blocks required under all post loads</p>	<p>E1 STAIR STRINGER</p> <p>Web filler (as backer block) minimum 12" long</p> <p>Filler block(s) minimum 4' long</p> <p>Approved connection (by others)</p> <p>See I-joist Header Cross-Section for connection information of the filler and backer blocks</p> <p>See I-joist Filler Schedule for filler block and web filler sizes</p>	<p>E2 HANGER DETAIL</p> <p>Applied loads at end of I-joist must be supported directly by the girder, or by a ledger or blocking fastened to the girder.</p> <p>Be sure to check web filler requirements for hangers</p> <p>Verify capacity and fastening requirements of hangers and connectors</p>
--	--	--

Floor Details

E3 I-JOIST HEADER

Verify web filler/stiffener requirements for hangers

See Double I-Joist Connection detail

Verify all hanger connections

Filler blocks

Web filler (as backer block)

Filler blocks

See I-Joist Header Cross-Section for information on attaching web fillers and filler blocks

Refer to I-Joist Filler Thickness table for web filler (backer block) and filler block sizes

E5 DOUBLE I-JOIST CONNECTION

Floor sheathing to be glued and nailed to flanges of both plies

6" oc

6" oc

Filler block

See I-Joist Header Cross-Section for information on attaching filler blocks

Refer to I-Joist Filler Thickness table for filler block sizes

E4 I-JOIST HEADER CROSS-SECTION

Backer Block (or Web Filler)

Verify web filler/stiffener requirements for hangers

Filler block(s)

Supported hanger (top-mount shown)

Filler Blocks:
Fasten I-joists together with filler blocks between the LPI webs using 2 rows of 0.131"x3.25" nails at 6" o.c. from both sides, stagger rows, and clinch where possible. Refer to the I-Joist Filler Thickness table for the correct filler block thickness for each LPI series. Filler blocks must be at least 4' long, located at each support, and centered behind each hanger. For joists supporting only top loads that are equally applied to both plies, filler blocks can be spaced at 8' on center maximum.

Backer Blocks:
Fasten min. 12" long backer blocks at all hangers and concentrated loads, center backer block on load, using a minimum of 10 nails (0.131"x3.25", clinch where possible) spaced to avoid splitting with half the nails to each side of the center of the supported hanger. Refer to the I-Joist Filler Thickness table for the correct backer block thickness for each LPI series. For a single I-joist header, install backer blocks to both sides of the web. Backer blocks may be omitted for top-mount hangers supporting only downward loads not exceeding 250 lbs. Install backer blocks tight to top flange for top-mount hangers or top concentrated loads unevenly applied to both plies. Install tight to bottom flange for joists supporting face-mount hangers.

NOTES:

- For double LPI's the maximum "Side-Applied" unfactored loads for standard duration: Uniform Load = 520 plf, Concentrated Load = 1200 lbs. Loads may be increased with more nails, and adjusted for other load durations.
- Filler and backer blocks shall consist of APA Rated wood structural panel (OSB or plywood), 2 x lumber (SPF or better) or LP® SolidStart® LVL or OSB Rim Board.
- Filler and backer blocks for members that are top-loaded only, or for hangers that do not require nailing into the web, shall be at least 5-1/2" deep for I-joists to 11-7/8" deep, and shall be at least 7-1/4" deep for I-joists 14" and deeper. Otherwise filler blocks shall fit the clear distance between flanges with a gap of at least 1/8", but not more than 1".

Filler Block Example: Lumber fillers may be stacked to achieve the required depth. Two 2 x 8s may be stacked vertically to achieve the filler depth for an 18" deep I-joist (min. req. is 18"-3"-1"=14"). One row of nails must be in each row of stacked fillers.

Backer Block Example: Two pieces of 2 x 8 (min.) lumber, cut to the proper height, may be set vertically side-by-side to achieve the required minimum 12" length.

NON LOAD-BEARING CANTILEVER

OSB or equal closure

Uniform loads only

1/3 adjacent span (max.)

Adjacent span

See page 10 for load bearing cantilever details

BEVEL CUT/FIRE CUT

LPI blocking or other lateral support required at ends of I-Joist

Bevel cut may not extend beyond inside face of bearing wall

I-JOIST FILLER THICKNESS		
Series	Filler Block	Web Filler/Backer Block
LPI 36	1-7/8"	7/8"
LPI 42Plus LPI 52Plus LPI 56	3"	1-1/2"

- GENERAL NOTES:**
- Some wind or seismic loads may require different or additional details and connections.
 - Verify building code requirements for suitability of details shown.
 - Refer to page 5 for bearing length requirements.
 - Refer to page 16 for Flange Nailing Schedule for LPI rim joist and blocking panel nailing.
 - Lateral support shall be considered for bottom flange when there is no sheathing on underside.
 - Verify capacity and fastening requirements of hangers and connectors.
 - Squash block capacity designed by others.
 - Do not use rim joists with flanges wider than 2-1/2".
- NOTES:**
- Backer blocks and filler blocks shall consist of APA Rated wood structural panel (OSB or plywood), or 2x lumber (SPF or better).
 - LP LVL or OSB Rim Board may also be used.
 - Refer to the Notes for the I-Joist Header Cross-Section above for details on the required height and length, and nailing of the backer blocks and filler blocks.

Web Stiffeners, Rim & Blocking, Nailing

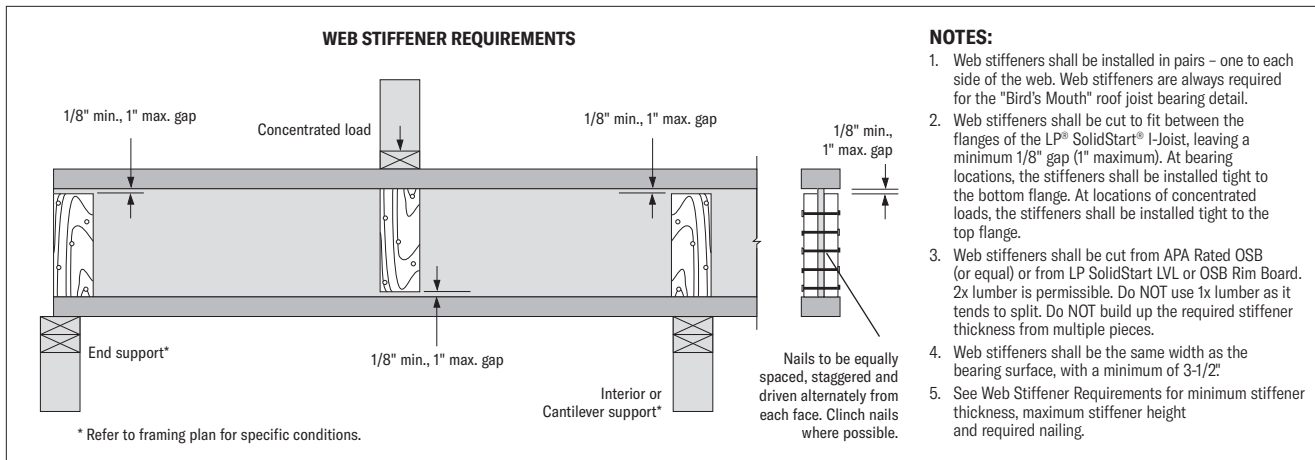

WEB STIFFENER REQUIREMENTS					
Series	Depth	Minimum Thickness	Maximum Height	Nail Size*	Nail Qty
LPI 36	11-7/8"	23/32"	8-3/4"	8d (2-1/2")	4
	14"	23/32"	10-7/8"	8d (2-1/2")	5
	16"	23/32"	12-7/8"	8d (2-1/2")	6
	18"	23/32"	14-7/8"	8d (2-1/2")	7
LPI 42Plus	11-7/8"	1-1/2"	8-3/4"	10d (3")	3
	14"	1-1/2"	10-7/8"	10d (3")	3
	16"	1-1/2"	12-7/8"	10d (3")	3
	18"	1-1/2"	14-7/8"	10d (3")	7
	20"	1-1/2"	16-7/8"	10d (3")	8
LPI 52Plus	11-7/8"	1-1/2"	8-3/4"	10d (3")	3
	14"	1-1/2"	10-7/8"	10d (3")	3
	16"	1-1/2"	12-7/8"	10d (3")	3
LPI 56	11-7/8"	1-1/2"	8-3/4"	10d (3")	4
	14"	1-1/2"	10-7/8"	10d (3")	5
	16"	1-1/2"	12-7/8"	10d (3")	6
	18"	1-1/2"	14-7/8"	10d (3")	7
	24"	1-1/2"	20-7/8"	10d (3")	10

* Nails may be Box or Common.

RIM & BLOCKING CAPACITY		
Series	Depth	Uniform Vertical Load Capacity
		(plf)
LPI 36	11-7/8"	1800
	14"	1800
	16"	1800
	18"	1300
LPI 42Plus	11-7/8"	2200
	14"	1600
	16"	1500
	18"	1700
	20"	1580
LPI 52Plus	11-7/8"	1100
	14"	2400
	16"	2200
LPI 56	11-7/8"	2400
	14"	2200
	16"	1900
	18"	1700
	24"	1100

NOTES:

1. Uniform Vertical Load Capacity shall not be adjusted for load duration.
2. Concentrated vertical loads require the addition of squash blocks. Do not use LPI rim or blocking to support concentrated vertical loads.
3. Lateral load capacity for all series above is 200 plf but may be limited by the connection details used. Do not exceed the Flange Face Nailing requirements at right.

FLANGE FACE NAILING			
Series	Nail Size and Type	Minimum Nail Distance	
		oc Spacing	End
LPI 42Plus LPI 52Plus	8d (2-1/2") Box or Common	2"	1"
	10d (3") or 12d (3-1/4") Box	2"	1"
	10d (3") or 12d (3-1/4") Common	3"	1-1/2"
	16d Sinker (3-1/4")	3"	1-1/2"
	16d (3-1/2") Box or Common	4"	1-1/2"
LPI 36 LPI 56	8d (2-1/2") Box or Common	3"	1-1/2"
	10d (3") or 12d (3-1/4") Box	3"	1-1/2"
	10d (3") or 12d (3-1/4") Common	3"	1-1/2"
	16d Sinker (3-1/4")	3"	1-1/2"
	16d (3-1/2") Box or Common	5"	1-1/2"

NOTES:

1. Use only 10d box or 8d nails when securing an LPI floor or roof joist to its supports.

Web Hole Specifications

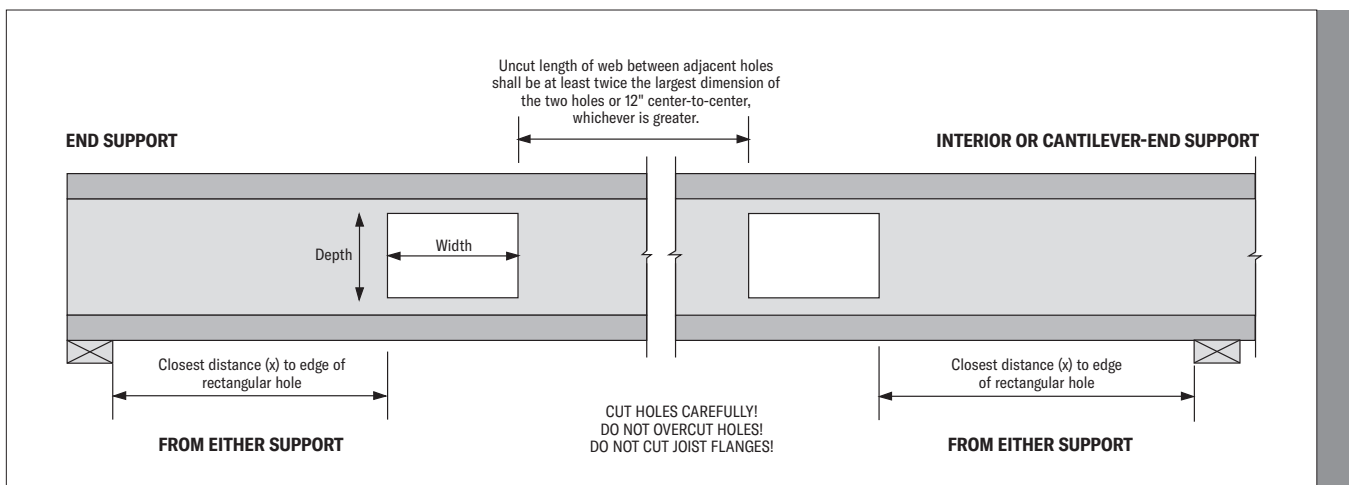
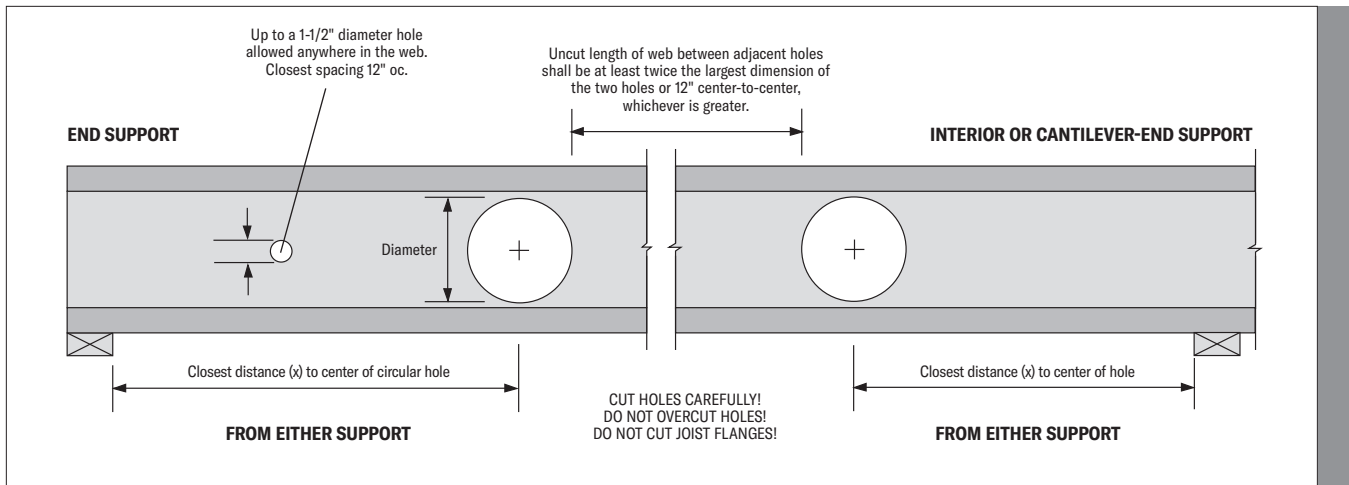

DESIGN ASSUMPTIONS:

- The hole locations listed above are valid for floor joists supporting only uniform loads. The total uniform load shall not exceed 190 plf (e.g., 50 psf Live Load and 25 psf Dead Load with a 20 psf Partition Load, spaced 24" oc). The uniform Dead Load shall be at least 25 plf. An additional concentrated "safe" load of 2000 lbs. acting over 6.25 ft² (2.5x2.5') has also been included.
- Hole location is measured from the inside face of bearing to the center of a circular hole, or to the nearest edge of a rectangular hole, from the closest support.
- Clear Span has not been verified for these joists and is shown for informational purposes only! Verify that the joist selected will work for the span and loading conditions needed before checking hole location.
- The maximum hole diameter for circular holes and depth for rectangular holes is the I-joist Depth less 4", except the maximum hole depth is 8" for 11-7/8" LPI joists. Maximum hole width for rectangular holes is 18". Where the Maximum Hole Dimension for rectangular holes exceeds the maximum hole depth, the dimension refers to hole width, and the hole depth is assumed to be the maximum for that joist depth.
- Holes cannot be located in the span where designated "-", without further analysis by a design professional.

NOTES:

- Holes may be placed anywhere within the depth of the joist. A minimum 1/4" clear distance from the flanges is recommended so as not to cut a flange.
- Round holes up to 1-1/2" diameter may be placed anywhere in the web.
- Perforated "knockouts" may be neglected when locating web holes.
- Holes larger than 1-1/2" are not permitted in cantilevers without special engineering.
- Multiple holes shall have a clear separation along the length of the joist of at least twice the larger dimension of the larger adjacent hole, or a minimum of 12" center-to-center, whichever is greater.
- Multiple holes may be spaced closer provided they fit within the boundary of an acceptable larger hole. Example: two 3" high by 8" long rectangle or an 8" diameter round hole are acceptable for the joist depth at that location and completely encompass the holes.
- For conditions not covered in this table, use LP's design software or contact your local LP® SolidStart® Engineered Wood Products distributor for more information.

Web Hole Specifications: Circular Holes

TO USE:

1. Select the required series and depth.
2. Determine the support condition for the nearest bearing: end support or interior support (including cantilever-end supports).
3. Select the row corresponding to the required clear span. For clear spans between those listed, use the next largest value.
4. Select the column corresponding to the required hole diameter. For diameters between those listed, use the next largest value.
5. The intersection of the Span row and Hole Diameter column gives the minimum distance from the inside face of bearing to the center of a circular hole.
6. Double check the distance to the other support, using the appropriate support condition.

Series	Depth	Clear Span	Distance from End Support								Distance from Interior or Cantilever-End Support								
			Hole Diameter								Hole Diameter								
			2"	4"	6"	8"	10"	12"	14"	16"	18"	2"	4"	6"	8"	10"	12"	14"	16"
LPI 36 LPI 56	11-7/8"	10'	1'-6"	2'-7"	3'-9"	4'-10"	-	-	-	-	2'-7"	3'-8"	4'-9"	-	-	-	-	-	-
		12'	2'-3"	3'-6"	4'-9"	6'-0"	-	-	-	-	3'-6"	4'-9"	5'-11"	-	-	-	-	-	-
		14'	3'-0"	4'-4"	5'-9"	-	-	-	-	-	4'-6"	5'-11"	-	-	-	-	-	-	-
		16'	3'-10"	5'-3"	6'-9"	-	-	-	-	-	5'-7"	7'-0"	-	-	-	-	-	-	-
		18'	4'-8"	6'-2"	7'-9"	-	-	-	-	-	6'-8"	8'-2"	-	-	-	-	-	-	-
		22'	6'-4"	8'-0"	9'-9"	-	-	-	-	-	7'-8"	9'-3"	-	-	-	-	-	-	-
	14"	14'	2'-10"	4'-0"	5'-1"	6'-3"	-	-	-	-	4'-4"	5'-6"	6'-7"	-	-	-	-	-	-
		16'	3'-7"	4'-10"	6'-1"	7'-3"	-	-	-	-	5'-4"	6'-7"	7'-9"	-	-	-	-	-	-
		18'	4'-5"	5'-8"	7'-0"	8'-4"	-	-	-	-	6'-5"	7'-8"	8'-11"	-	-	-	-	-	-
		20'	5'-3"	6'-7"	8'-0"	9'-4"	-	-	-	-	7'-6"	8'-10"	-	-	-	-	-	-	-
		22'	6'-1"	7'-6"	8'-11"	10'-4"	-	-	-	-	8'-7"	9'-11"	-	-	-	-	-	-	-
		24'	6'-11"	8'-5"	9'-11"	11'-5"	-	-	-	-	9'-8"	11'-1"	-	-	-	-	-	-	-
	16"	18'	4'-3"	5'-5"	6'-6"	7'-8"	8'-10"	-	-	-	6'-3"	7'-4"	8'-6"	-	-	-	-	-	-
		20'	5'-1"	6'-3"	7'-6"	8'-8"	9'-10"	-	-	-	7'-4"	8'-6"	9'-8"	-	-	-	-	-	-
		22'	5'-11"	7'-2"	8'-5"	9'-8"	10'-11"	-	-	-	8'-4"	9'-7"	10'-10"	-	-	-	-	-	-
		24'	6'-9"	8'-1"	9'-4"	10'-8"	11'-11"	-	-	-	9'-6"	10'-9"	12'-0"	-	-	-	-	-	-
		26'	7'-7"	8'-11"	10'-4"	11'-8"	13'-0"	-	-	-	10'-7"	11'-11"	-	-	-	-	-	-	-
		30'	9'-5"	10'-10"	12'-3"	13'-8"	-	-	-	-	12'-10"	14'-2"	-	-	-	-	-	-	-
	18"	22'	1'-2"	2'-11"	4'-8"	6'-4"	8'-1"	9'-9"	-	-	3'-6"	5'-4"	7'-1"	8'-10"	10'-6"	-	-	-	-
		24'	1'-11"	3'-8"	5'-5"	7'-2"	9'-0"	10'-9"	-	-	4'-5"	6'-4"	8'-2"	9'-11"	11'-8"	-	-	-	-
		26'	2'-7"	4'-5"	6'-3"	8'-1"	9'-11"	11'-9"	-	-	5'-5"	7'-4"	9'-2"	11'-0"	12'-10"	-	-	-	-
		28'	3'-4"	5'-2"	7'-1"	9'-0"	10'-10"	12'-9"	-	-	6'-5"	8'-4"	10'-3"	12'-2"	14'-0"	-	-	-	-
		30'	4'-1"	6'-0"	7'-11"	9'-11"	11'-10"	13'-9"	-	-	7'-5"	9'-5"	11'-5"	13'-4"	-	-	-	-	-
		32'	4'-10"	6'-10"	8'-10"	10'-9"	12'-9"	14'-9"	-	-	8'-5"	10'-6"	12'-6"	14'-5"	-	-	-	-	-
	LPI 42Plus LPI 52Plus	11-7/8"	10'	2'-6"	3'-3"	3'-11"	4'-8"	-	-	-	3'-7"	4'-3"	4'-11"	-	-	-	-	-	-
			12'	3'-4"	4'-2"	4'-11"	5'-9"	-	-	-	4'-8"	5'-5"	-	-	-	-	-	-	-
			14'	4'-3"	5'-1"	6'-0"	6'-10"	-	-	-	5'-9"	6'-7"	-	-	-	-	-	-	-
			16'	5'-1"	6'-1"	7'-0"	7'-11"	-	-	-	6'-10"	7'-9"	-	-	-	-	-	-	-
			18'	6'-0"	7'-0"	8'-0"	9'-0"	-	-	-	8'-0"	8'-11"	-	-	-	-	-	-	-
			22'	7'-10"	8'-11"	10'-0"	-	-	-	-	10'-3"	-	-	-	-	-	-	-	-
		14"	14'	4'-1"	4'-10"	5'-7"	6'-4"	-	-	-	5'-7"	6'-4"	7'-0"	-	-	-	-	-	-
			16'	5'-0"	5'-9"	6'-7"	7'-4"	-	-	-	6'-9"	7'-6"	-	-	-	-	-	-	-
			18'	5'-10"	6'-8"	7'-7"	8'-5"	-	-	-	7'-10"	8'-8"	-	-	-	-	-	-	-
			20'	6'-9"	7'-8"	8'-6"	9'-5"	-	-	-	9'-0"	9'-10"	-	-	-	-	-	-	-
			22'	7'-8"	8'-7"	9'-6"	10'-5"	-	-	-	10'-1"	11'-0"	-	-	-	-	-	-	-
			24'	8'-7"	9'-7"	10'-6"	11'-6"	-	-	-	11'-3"	-	-	-	-	-	-	-	-
16"		18'	5'-9"	6'-6"	7'-3"	8'-0"	8'-8"	-	-	7'-9"	8'-5"	-	-	-	-	-	-	-	
		20'	6'-8"	7'-5"	8'-2"	9'-0"	9'-9"	-	-	8'-10"	9'-7"	-	-	-	-	-	-	-	
		22'	7'-7"	8'-4"	9'-2"	10'-0"	10'-9"	-	-	10'-0"	10'-9"	-	-	-	-	-	-	-	
		24'	8'-6"	9'-4"	10'-2"	11'-0"	11'-10"	-	-	11'-2"	12'-0"	-	-	-	-	-	-	-	
		26'	9'-5"	10'-3"	11'-2"	12'-0"	12'-10"	-	-	12'-4"	-	-	-	-	-	-	-	-	
		30'	11'-3"	12'-2"	13'-1"	14'-0"	14'-11"	-	-	14'-8"	-	-	-	-	-	-	-	-	
LPI 42Plus		18"	22'	1'-2"	2'-11"	4'-8"	6'-4"	8'-1"	9'-9"	-	-	3'-6"	5'-4"	7'-1"	8'-10"	10'-6"	-	-	-
			24'	1'-11"	3'-8"	5'-5"	7'-2"	9'-0"	10'-9"	-	-	4'-5"	6'-4"	8'-2"	9'-11"	11'-8"	-	-	-
			26'	2'-7"	4'-5"	6'-3"	8'-1"	9'-11"	11'-9"	-	-	5'-5"	7'-4"	9'-2"	11'-0"	12'-10"	-	-	-
			28'	3'-4"	5'-2"	7'-1"	9'-0"	10'-10"	12'-9"	-	-	6'-5"	8'-4"	10'-3"	12'-2"	14'-0"	-	-	-
			30'	4'-1"	6'-0"	7'-11"	9'-11"	11'-10"	13'-9"	-	-	7'-5"	9'-5"	11'-5"	13'-4"	-	-	-	-
			32'	4'-10"	6'-10"	8'-10"	10'-9"	12'-9"	14'-9"	-	-	8'-5"	10'-6"	12'-6"	14'-5"	-	-	-	-
		20"	22'	1'-0"	2'-7"	4'-1"	5'-8"	7'-2"	8'-9"	10'-3"	-	3'-3"	4'-11"	6'-7"	8'-2"	9'-8"	-	-	-
			24'	1'-8"	3'-4"	4'-11"	6'-6"	8'-1"	9'-8"	11'-3"	-	4'-3"	5'-11"	7'-7"	9'-3"	10'-9"	-	-	-
			26'	2'-5"	4'-1"	5'-8"	7'-4"	9'-0"	10'-8"	12'-4"	-	5'-2"	6'-11"	8'-8"	10'-4"	11'-11"	-	-	-
			28'	3'-2"	4'-10"	6'-6"	8'-3"	9'-11"	11'-7"	13'-4"	-	6'-2"	8'-0"	9'-9"	11'-5"	13'-1"	-	-	-
			30'	3'-10"	5'-7"	7'-4"	9'-1"	10'-10"	12'-7"	14'-4"	-	7'-3"	9'-0"	10'-10"	12'-6"	14'-3"	-	-	-
			32'	4'-8"	6'-5"	8'-3"	10'-0"	11'-9"	13'-7"	15'-4"	-	8'-3"	10'-1"	11'-11"	13'-8"	15'-5"	-	-	-
		24"	26'	2'-2"	3'-6"	4'-11"	6'-3"	7'-8"	9'-0"	10'-5"	11'-9"	-	4'-11"	6'-4"	7'-10"	9'-2"	10'-7"	11'-11"	-
			28'	2'-10"	4'-3"	5'-8"	7'-1"	8'-6"	9'-11"	11'-4"	12'-9"	-	5'-11"	7'-5"	8'-10"	10'-3"	11'-8"	13'-1"	-
			30'	3'-7"	5'-0"	6'-6"	7'-11"	9'-5"	10'-10"	12'-4"	13'-9"	-	6'-11"	8'-5"	9'-11"	11'-5"	12'-10"	14'-3"	-
			32'	4'-4"	5'-10"	7'-4"	8'-10"	10'-4"	11'-9"	13'-3"	14'-9"	-	7'-11"	9'-6"	11'-0"	12'-6"	14'-0"	15'-5"	-
			34'	5'-2"	6'-8"	8'-2"	9'-8"	11'-2"	12'-8"	14'-3"	15'-9"	-	9'-0"	10'-6"	12'-1"	13'-7"	15'-1"	16'-7"	-
			36'	6'-0"	7'-6"	9'-0"	10'-7"	12'-1"	13'-8"	15'-2"	16'-9"	-	10'-1"	11'-7"	13'-2"	14'-9"	16'-3"	17'-9"	-
	38'	7'-2"	8'-6"	9'-11"	11'-5"	13'-0"	14'-7"	16'-2"	17'-11"	-	11'-4"	12'-8"	14'-4"	15'-10"	17'-5"	19'-0"	-		

Note: Refer to page 17 for the design assumptions and notes for this table.

* Applies to the 24" LPI 56

Roof Span Tables: Low Pitch (6:12 or less) for 20, 25 and 30 psf Load

TO USE:

1. Select the appropriate set of tables based on roof pitch.
2. Select the section of that table that corresponds to the design roof live load (snow or non-snow).
3. Find a span that meets or exceeds the design span for the appropriate roof dead load (15 psf or 20 psf).
4. Read the corresponding series, depth and spacing.

DESIGN ASSUMPTIONS:

1. The spans listed are the horizontal clear distance between supports and are valid for simple or continuous span applications. Continuous spans are based on the longest span. The shortest span shall not be less than 50% of the longest span.
2. The spans are based on uniform gravity loads only as listed for each table, including the effects of a 300 lb concentrated load. These spans have not been evaluated for wind.
3. These tables do not reflect any additional stiffness provided by the roof sheathing.
4. Live load deflection is limited to L/240.
5. Total load deflection is limited to L/180.
6. The spans are based on an end bearing length of at least 1-3/4" for depths up to 16" and at least 2-1/2" for depths greater than 16", an interior bearing length of at least 3-1/2", and are limited to the bearing capacity for an SPF wall plate ($F_{c\perp} = 425$ psi).

ADDITIONAL NOTES:

1. Web stiffeners are not required for the Roof Span tables except when using a "bird's mouth" detail for the low-end bearing. Web fillers are required for I-joists seated in hangers that do not laterally support the top flange or for hangers that require nailing into the web.
2. L/240 represents the maximum deflection allowed per code for roof joists supporting non-plaster ceilings. Verify deflection limits with local code requirements.
3. Roof joists shall have a minimum pitch of 1/4" per foot (1/4:12) for positive drainage.
4. Roof applications in high wind areas require special analysis which may reduce spans and may require bracing of the bottom flange and special connectors to resist uplift.
5. For conditions not shown, use the Uniform Roof Load (PLF) tables, LP's design software or contact your LP® SolidStart® Engineered Wood Products distributor for assistance.

	Series	Depth	16" oc		19.2" oc		24" oc			
			Roof Dead Load →		15 psf	20 psf	15 psf	20 psf	15 psf	20 psf
20 psf 115% Snow or 125% Non-Snow	LPI 36	11-7/8"	28'-0"	26'-8"	26'-3"	25'-0"	24'-4"	23'-2"		
		14"	31'-8"	30'-2"	29'-9"	28'-4"	27'-7"	26'-3"		
		16"	35'-0"	33'-4"	32'-10"	31'-4"	30'-5"	28'-5"		
		18"	38'-1"	36'-4"	35'-10"	34'-1"	32'-6"	28'-4"		
	LPI 42Plus	11-7/8"	30'-4"	28'-11"	28'-6"	27'-2"	26'-5"	25'-1"		
		14"	34'-6"	32'-10"	32'-5"	30'-10"	30'-0"	28'-7"		
		16"	38'-3"	36'-6"	36'-0"	34'-3"	33'-4"	31'-8"		
		18"	41'-0"	39'-1"	38'-6"	36'-8"	35'-8"	34'-0"		
	LPI 52Plus	11-7/8"	31'-4"	29'-11"	29'-6"	28'-1"	27'-3"	26'-0"		
		14"	35'-7"	33'-11"	33'-5"	31'-10"	31'-0"	29'-6"		
		16"	39'-5"	37'-7"	37'-0"	35'-3"	34'-3"	32'-8"		
		18"	44'-5"	42'-3"	41'-8"	39'-9"	38'-7"	36'-1"		
LPI 56	11-7/8"	32'-5"	30'-11"	30'-6"	29'-0"	28'-2"	26'-10"			
	14"	36'-9"	35'-0"	34'-6"	32'-10"	31'-11"	30'-5"			
	16"	40'-7"	38'-8"	38'-2"	36'-4"	35'-4"	31'-11"			
	18"	44'-3"	42'-1"	41'-6"	39'-7"	38'-5"	35'-3"			
25 psf 115% Snow	LPI 36	11-7/8"	26'-9"	25'-7"	25'-1"	24'-1"	23'-3"	22'-2"		
		14"	30'-4"	29'-0"	28'-6"	27'-3"	26'-4"	25'-3"		
		16"	33'-6"	32'-1"	31'-6"	30'-1"	28'-5"	25'-3"		
		18"	36'-6"	34'-11"	34'-3"	31'-7"	28'-5"	25'-2"		
	LPI 42Plus	11-7/8"	29'-0"	27'-10"	27'-3"	26'-1"	25'-3"	24'-2"		
		14"	33'-0"	31'-8"	31'-0"	29'-8"	28'-8"	27'-6"		
		16"	36'-8"	35'-1"	34'-5"	32'-11"	31'-10"	30'-5"		
		18"	39'-3"	37'-7"	36'-10"	35'-4"	34'-2"	32'-5"		
	LPI 52Plus	11-7/8"	30'-0"	28'-9"	28'-2"	27'-0"	26'-1"	25'-0"		
		14"	34'-1"	32'-8"	32'-0"	30'-8"	29'-8"	28'-5"		
		16"	37'-9"	36'-2"	35'-5"	33'-11"	32'-10"	31'-5"		
		18"	41'-1"	39'-9"	39'-2"	37'-11"	36'-11"	35'-10"		
LPI 56	11-7/8"	31'-1"	29'-9"	29'-2"	27'-11"	27'-0"	25'-10"			
	14"	35'-2"	33'-8"	33'-0"	31'-7"	30'-7"	28'-5"			
	16"	38'-10"	37'-2"	36'-6"	34'-11"	32'-4"	28'-6"			
	18"	42'-4"	40'-6"	40'-6"	38'-1"	35'-7"	31'-6"			
30 psf 115% Snow	LPI 36	11-7/8"	25'-9"	24'-9"	24'-2"	23'-3"	22'-4"	21'-6"		
		14"	29'-2"	28'-1"	27'-5"	26'-4"	25'-3"	22'-8"		
		16"	32'-3"	31'-0"	30'-3"	28'-5"	25'-3"	22'-8"		
		18"	35'-1"	33'-9"	31'-7"	28'-4"	25'-2"	22'-7"		
	LPI 42Plus	11-7/8"	27'-11"	26'-10"	26'-3"	25'-2"	24'-3"	23'-4"		
		14"	31'-9"	30'-7"	29'-10"	28'-8"	27'-7"	26'-6"		
		16"	35'-3"	33'-11"	33'-1"	31'-10"	30'-8"	29'-0"		
		18"	37'-9"	36'-4"	35'-5"	34'-1"	32'-8"	30'-10"		
	LPI 52Plus	11-7/8"	28'-11"	27'-9"	27'-1"	26'-1"	25'-1"	24'-2"		
		14"	32'-9"	31'-6"	30'-9"	29'-7"	28'-6"	27'-5"		
		16"	36'-3"	34'-11"	34'-1"	32'-9"	31'-7"	30'-4"		
		18"	39'-10"	38'-5"	37'-11"	36'-4"	34'-4"	31'-4"		
LPI 56	11-7/8"	29'-10"	28'-9"	28'-0"	26'-11"	25'-11"	24'-11"			
	14"	33'-10"	32'-6"	31'-9"	30'-6"	28'-10"	25'-8"			
	16"	37'-4"	35'-11"	35'-1"	32'-3"	28'-10"	25'-9"			
	18"	40'-8"	39'-2"	38'-3"	35'-7"	31'-7"	28'-5"			
		24"	47'-7"	42'-10"	39'-7"	35'-7"	31'-7"	28'-5"		

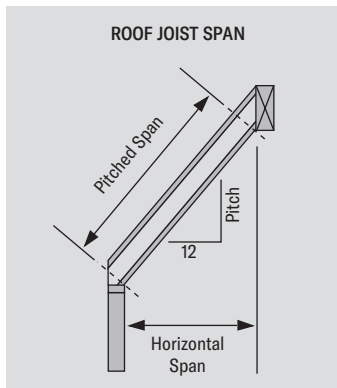

ACTUAL DEFLECTION BASED ON SPAN AND LIMIT			
Span (ft)	L/360	L/240	L/180
10'	5/16"	1/2"	11/16"
12'	3/8"	5/8"	13/16"
14'	7/16"	11/16"	15/16"
16'	9/16"	13/16"	1-1/16"
18'	5/8"	7/8"	1-3/16"
20'	11/16"	1"	1-5/16"
22'	3/4"	1-1/8"	1-7/16"
24'	13/16"	1-3/16"	1-5/8"
26'	7/8"	1-5/16"	1-3/4"
28'	15/16"	1-3/8"	1-7/8"
30'	1"	1-1/2"	2"

* Deflections rounded to the nearest 1/16".

Roof Span Tables: Low Pitch (6:12 or less) for 40, 50 and 60 psf Load

TO USE:

1. Select the appropriate set of tables based on roof pitch.
2. Select the section of that table that corresponds to the design roof live load (snow or non-snow).
3. Find a span that meets or exceeds the design span for the appropriate roof dead load (15 psf or 20 psf).
4. Read the corresponding series, depth and spacing.

DESIGN ASSUMPTIONS:

1. The spans listed are the horizontal clear distance between supports and are valid for simple or continuous span applications. Continuous spans are based on the longest span. The shortest span shall not be less than 50% of the longest span.
2. The spans are based on uniform gravity loads only as listed for each table, including the effects of a 300 lb concentrated load. These spans have not been evaluated for wind.
3. These tables do not reflect any additional stiffness provided by the roof sheathing.
4. Live load deflection is limited to L/240.
5. Total load deflection is limited to L/180.
6. The spans are based on an end bearing length of at least 1-3/4" for depths up to 16" and at least 2-1/2" for depths greater than 16", an interior bearing length of at least 3-1/2", and are limited to the bearing capacity for an SPF wall plate ($F_{c\perp} = 425$ psi).

ADDITIONAL NOTES:

1. Web stiffeners are not required for the Roof Span tables except when using a "bird's mouth" detail for the low-end bearing. Web fillers are required for I-joists seated in hangers that do not laterally support the top flange or for hangers that require nailing into the web.
2. L/240 represents the maximum deflection allowed per code for roof joists supporting non-plaster ceilings. Verify deflection limits with local code requirements.
3. Roof joists shall have a minimum pitch of 1/4" per foot (1/4:12) for positive drainage.
4. Roof applications in high wind areas require special analysis which may reduce spans and may require bracing of the bottom flange and special connectors to resist uplift.
5. For conditions not shown, use the Uniform Roof Load (PLF) tables, LP's design software or contact your LP® SolidStart® Engineered Wood Products distributor for assistance.

	Series	Depth	16" oc		19.2" oc		24" oc			
			Roof Dead Load →		15 psf	20 psf	15 psf	20 psf	15 psf	20 psf
ROOF LIVE LOAD	40 psf 115% Snow	LPI 36	11'-7/8"	24'-1"	23'-3"	22'-7"	21'-10"	20'-7"	18'-10"	
			14"	27'-3"	26'-5"	25'-7"	23'-8"	20'-7"	18'-10"	
			16"	30'-2"	28'-5"	25'-10"	23'-8"	20'-7"	18'-10"	
			18"	31'-0"	28'-4"	25'-9"	23'-7"	20'-6"	18'-9"	
		LPI 42Plus	11'-7/8"	26'-1"	25'-3"	24'-6"	23'-9"	22'-8"	21'-11"	
			14"	29'-8"	28'-9"	27'-11"	27'-0"	25'-9"	23'-9"	
	16"		33'-0"	31'-11"	30'-11"	29'-8"	26'-10"	24'-7"		
	18"		35'-4"	34'-2"	33'-1"	31'-7"	28'-6"	26'-1"		
	LPI 52Plus	11'-7/8"	27'-0"	26'-2"	25'-4"	24'-7"	23'-6"	22'-8"		
		14"	30'-8"	29'-8"	28'-9"	27'-10"	26'-8"	25'-9"		
		16"	33'-11"	32'-10"	31'-11"	30'-10"	28'-6"	26'-1"		
		18"	35'-11"	34'-10"	33'-11"	32'-8"	28'-6"	26'-1"		
LPI 56	11'-7/8"	27'-11"	27'-0"	26'-2"	25'-4"	23'-8"	21'-6"			
	14"	31'-8"	30'-7"	29'-8"	27'-0"	25'-9"	23'-9"			
	16"	34'-11"	32'-6"	29'-9"	27'-0"	23'-9"	21'-7"			
	18"	38'-1"	35'-7"	32'-4"	29'-7"	25'-9"	23'-7"			
50 psf 115% Snow	LPI 36	11'-7/8"	22'-9"	22'-1"	21'-4"	20'-2"	17'-4"	16'-1"		
		14"	25'-9"	24'-4"	21'-9"	20'-2"	17'-4"	16'-1"		
		16"	26'-2"	24'-4"	21'-9"	20'-2"	17'-4"	16'-1"		
		18"	26'-2"	24'-3"	21'-9"	20'-2"	17'-4"	16'-0"		
	LPI 42Plus	11'-7/8"	24'-8"	24'-0"	23'-2"	22'-6"	21'-1"	19'-7"		
		14"	28'-1"	27'-4"	26'-4"	25'-6"	21'-11"	20'-4"		
		16"	31'-2"	30'-3"	28'-4"	27'-4"	22'-8"	21'-0"		
		18"	33'-5"	32'-1"	30'-1"	27'-11"	24'-0"	22'-3"		
	LPI 52Plus	11'-7/8"	25'-6"	24'-10"	24'-0"	23'-4"	22'-2"	21'-7"		
		14"	29'-0"	28'-2"	27'-3"	26'-6"	24'-0"	22'-3"		
		16"	32'-1"	31'-3"	30'-2"	28'-0"	24'-1"	22'-4"		
		18"	32'-10"	31'-5"	30'-5"	27'-4"	25'-4"	21'-9"		
LPI 56	11'-7/8"	26'-5"	25'-8"	24'-9"	23'-2"	20'-1"	18'-6"			
	14"	29'-11"	27'-11"	25'-2"	23'-3"	20'-1"	18'-6"			
	16"	30'-4"	28'-0"	25'-3"	23'-3"	20'-1"	18'-7"			
	18"	32'-10"	30'-5"	27'-4"	25'-4"	21'-9"	20'-2"			
60 psf 115% Snow	LPI 36	11'-7/8"	21'-4"	21'-1"	18'-10"	17'-8"	15'-0"	14'-1"		
		14"	22'-8"	21'-3"	18'-10"	17'-8"	15'-0"	14'-1"		
		16"	22'-8"	21'-3"	18'-10"	17'-8"	15'-0"	14'-1"		
		18"	22'-7"	21'-2"	18'-9"	17'-7"	14'-11"	14'-0"		
	LPI 42Plus	11'-7/8"	23'-2"	22'-11"	21'-9"	21'-5"	18'-3"	17'-1"		
		14"	26'-4"	26'-1"	23'-9"	22'-3"	18'-11"	17'-9"		
		16"	29'-3"	27'-8"	24'-7"	23'-0"	19'-7"	18'-4"		
		18"	31'-2"	29'-4"	26'-1"	24'-5"	20'-9"	19'-5"		
	LPI 52Plus	11'-7/8"	24'-0"	23'-9"	22'-6"	22'-3"	20'-8"	19'-3"		
		14"	27'-3"	26'-11"	25'-7"	24'-4"	20'-9"	19'-5"		
		16"	30'-2"	29'-5"	26'-1"	24'-6"	20'-10"	19'-6"		
		18"	31'-4"	29'-4"	26'-1"	24'-5"	20'-9"	19'-5"		
LPI 56	11'-7/8"	24'-9"	24'-5"	21'-10"	20'-4"	17'-5"	16'-2"			
	14"	26'-4"	24'-6"	21'-10"	20'-4"	17'-5"	16'-3"			
	16"	26'-4"	24'-6"	21'-11"	20'-5"	17'-6"	16'-3"			
	18"	28'-5"	26'-7"	23'-7"	22'-1"	18'-10"	17'-7"			
		24"	28'-5"	26'-7"	23'-7"	22'-1"	18'-10"	17'-7"		

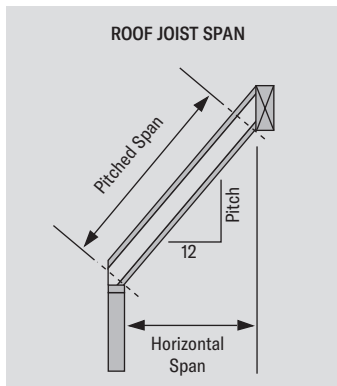

ACTUAL DEFLECTION BASED ON SPAN AND LIMIT			
Span (ft)	L/360	L/240	L/180
10'	5/16"	1/2"	11/16"
12'	3/8"	5/8"	13/16"
14'	7/16"	11/16"	15/16"
16'	9/16"	13/16"	1-1/16"
18'	5/8"	7/8"	1-3/16"
20'	11/16"	1"	1-5/16"
22'	3/4"	1-1/8"	1-7/16"
24'	13/16"	1-3/16"	1-5/8"
26'	7/8"	1-5/16"	1-3/4"
28'	15/16"	1-3/8"	1-7/8"
30'	1"	1-1/2"	2"

* Deflections rounded to the nearest 1/16".

Roof Span Tables: High Pitch (6:12 to 12:12) for 20, 25 and 30 psf Load

TO USE:

1. Select the appropriate set of tables based on roof pitch.
2. Select the section of that table that corresponds to the design roof live load (snow or non-snow).
3. Find a span that meets or exceeds the design span for the appropriate roof dead load (15 psf or 20 psf).
4. Read the corresponding series, depth and spacing.

DESIGN ASSUMPTIONS:

1. The spans listed are the horizontal clear distance between supports and are valid for simple or continuous span applications. Continuous spans are based on the longest span. The shortest span shall not be less than 50% of the longest span.
2. The spans are based on uniform gravity loads only as listed for each table, including the effects of a 300 lb concentrated load. These spans have not been evaluated for wind.
3. These tables do not reflect any additional stiffness provided by the roof sheathing.
4. Live load deflection is limited to L/240.
5. Total load deflection is limited to L/180.
6. The spans are based on an end bearing length of at least 1-3/4" for depths up to 16" and at least 2-1/2" for depths greater than 16", an interior bearing length of at least 3-1/2", and are limited to the bearing capacity for an SPF wall plate ($F_{c\perp} = 425$ psi).

ADDITIONAL NOTES:

1. Web stiffeners are not required for the Roof Span tables except when using a "bird's mouth" detail for the low-end bearing. Web fillers are required for I-joists seated in hangers that do not laterally support the top flange or for hangers that require nailing into the web.
2. L/240 represents the maximum deflection allowed per code for roof joists supporting non-plaster ceilings. Verify deflection limits with local code requirements.
3. Roof joists shall have a minimum pitch of 1/4" per foot (1/4:12) for positive drainage.
4. Roof applications in high wind areas require special analysis which may reduce spans and may require bracing of the bottom flange and special connectors to resist uplift.
5. For conditions not shown, use the Uniform Roof Load (PLF) tables, LP's design software or contact your LP® SolidStart® Engineered Wood Products distributor for assistance.

	Series	Depth	16" oc		19.2" oc		24" oc			
			Roof Dead Load →		15 psf	20 psf	15 psf	20 psf	15 psf	20 psf
20 psf 115% Snow or 125% Non-Snow	LPI 36	11-7/8"	25'-0"	23'-8"	23'-6"	22'-3"	21'-9"	20'-7"		
		14"	28'-4"	26'-10"	26'-7"	25'-2"	24'-7"	23'-4"		
		16"	31'-3"	29'-7"	29'-4"	27'-10"	27'-2"	25'-0"		
		18"	34'-0"	32'-3"	32'-0"	30'-3"	29'-7"	27'-8"		
	LPI 42Plus	11-7/8"	27'-1"	25'-8"	25'-5"	24'-1"	23'-7"	22'-4"		
		14"	30'-10"	29'-2"	28'-11"	27'-5"	26'-10"	25'-5"		
		16"	34'-2"	32'-5"	32'-1"	30'-5"	29'-9"	28'-2"		
		18"	36'-7"	34'-8"	34'-4"	32'-7"	31'-10"	30'-2"		
	LPI 52Plus	11-7/8"	28'-0"	26'-6"	26'-4"	24'-11"	24'-4"	23'-1"		
		14"	31'-9"	30'-1"	29'-10"	28'-3"	27'-8"	26'-2"		
		16"	35'-2"	33'-4"	33'-1"	31'-4"	30'-7"	29'-0"		
		18"	39'-7"	37'-6"	37'-3"	35'-3"	34'-6"	32'-8"		
LPI 56	11-7/8"	29'-0"	27'-5"	27'-3"	25'-9"	25'-2"	23'-10"			
	14"	32'-10"	31'-1"	30'-10"	29'-2"	28'-7"	27'-0"			
	16"	36'-3"	34'-4"	34'-1"	32'-3"	31'-6"	28'-0"			
	18"	39'-6"	37'-5"	37'-1"	35'-2"	34'-4"	31'-0"			
25 psf 115% Snow	LPI 36	11-7/8"	24'-0"	22'-10"	22'-7"	21'-6"	20'-11"	19'-11"		
		14"	27'-2"	25'-11"	25'-7"	24'-4"	23'-8"	22'-6"		
		16"	30'-1"	28'-7"	28'-3"	26'-11"	26'-1"	22'-7"		
		18"	32'-9"	31'-2"	30'-9"	29'-3"	28'-6"	25'-0"		
	LPI 42Plus	11-7/8"	26'-1"	24'-10"	24'-6"	23'-4"	22'-8"	21'-7"		
		14"	29'-8"	28'-3"	27'-10"	26'-6"	25'-9"	24'-9"		
		16"	32'-10"	31'-4"	30'-11"	29'-5"	28'-7"	27'-9"		
		18"	35'-2"	33'-6"	33'-1"	31'-6"	30'-8"	29'-2"		
	LPI 52Plus	11-7/8"	26'-11"	25'-8"	25'-4"	24'-1"	23'-5"	22'-4"		
		14"	30'-7"	29'-1"	28'-8"	27'-4"	26'-7"	25'-4"		
		16"	33'-10"	32'-3"	31'-9"	30'-3"	29'-5"	28'-0"		
		18"	37'-10"	36'-6"	36'-2"	34'-11"	34'-3"	32'-1"		
LPI 56	11-7/8"	27'-10"	26'-6"	26'-2"	24'-11"	24'-3"	23'-1"			
	14"	31'-7"	30'-1"	29'-8"	28'-3"	27'-5"	25'-4"			
	16"	34'-10"	33'-2"	32'-9"	31'-2"	29'-3"	25'-4"			
	18"	37'-11"	36'-2"	35'-8"	34'-0"	32'-5"	28'-1"			
30 psf 115% Snow	LPI 36	11-7/8"	23'-2"	22'-2"	21'-9"	20'-10"	20'-2"	19'-3"		
		14"	26'-3"	25'-1"	24'-8"	23'-7"	22'-10"	20'-7"		
		16"	29'-0"	27'-9"	27'-3"	25'-10"	23'-6"	20'-8"		
		18"	31'-7"	30'-3"	29'-8"	28'-5"	26'-1"	22'-10"		
	LPI 42Plus	11-7/8"	25'-2"	24'-1"	23'-7"	22'-7"	21'-10"	20'-11"		
		14"	28'-7"	27'-4"	26'-10"	25'-8"	24'-11"	23'-9"		
		16"	31'-9"	30'-4"	29'-10"	28'-6"	27'-7"	26'-5"		
		18"	34'-0"	32'-6"	31'-11"	30'-6"	29'-7"	28'-3"		
	LPI 52Plus	11-7/8"	26'-0"	24'-10"	24'-5"	23'-4"	22'-7"	21'-8"		
		14"	29'-6"	28'-3"	27'-9"	26'-6"	25'-8"	24'-7"		
		16"	32'-8"	31'-3"	30'-8"	29'-4"	28'-5"	27'-2"		
		18"	36'-9"	35'-2"	34'-7"	33'-1"	32'-0"	29'-3"		
LPI 56	11-7/8"	26'-11"	25'-9"	25'-3"	24'-2"	23'-5"	22'-4"			
	14"	30'-6"	29'-2"	28'-7"	27'-4"	26'-4"	23'-1"			
	16"	33'-8"	32'-2"	31'-7"	29'-0"	26'-5"	23'-2"			
	18"	36'-8"	35'-1"	34'-5"	32'-1"	29'-2"	25'-7"			
		24"	44'-10"	39'-4"	37'-3"	32'-9"	29'-9"	26'-1"		

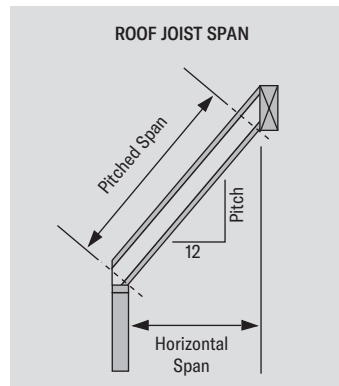

ACTUAL DEFLECTION BASED ON SPAN AND LIMIT			
Span (ft)	L/360	L/240	L/180
10'	5/16"	1/2"	11/16"
12'	3/8"	5/8"	13/16"
14'	7/16"	11/16"	15/16"
16'	9/16"	13/16"	1-1/16"
18'	5/8"	7/8"	1-3/16"
20'	11/16"	1"	1-5/16"
22'	3/4"	1-1/8"	1-7/16"
24'	13/16"	1-3/16"	1-5/8"
26'	7/8"	1-5/16"	1-3/4"
28'	15/16"	1-3/8"	1-7/8"
30'	1"	1-1/2"	2"

* Deflections rounded to the nearest 1/16".

Roof Span Tables: High Pitch (6:12 to 12:12) for 40, 50 and 60 psf Load

TO USE:

1. Select the appropriate set of tables based on roof pitch.
2. Select the section of that table that corresponds to the design roof live load (snow or non-snow).
3. Find a span that meets or exceeds the design span for the appropriate roof dead load (15 psf or 20 psf).
4. Read the corresponding series, depth and spacing.

DESIGN ASSUMPTIONS:

1. The spans listed are the horizontal clear distance between supports and are valid for simple or continuous span applications. Continuous spans are based on the longest span. The shortest span shall not be less than 50% of the longest span.
2. The spans are based on uniform gravity loads only as listed for each table, including the effects of a 300 lb concentrated load. These spans have not been evaluated for wind.
3. These tables do not reflect any additional stiffness provided by the roof sheathing.
4. Live load deflection is limited to L/240.
5. Total load deflection is limited to L/180.
6. The spans are based on an end bearing length of at least 1-3/4" for depths up to 16" and at least 2-1/2" for depths greater than 16", an interior bearing length of at least 3-1/2", and are limited to the bearing capacity for an SPF wall plate ($F_{c\perp} = 425$ psi).

ADDITIONAL NOTES:

1. Web stiffeners are not required for the Roof Span tables except when using a "bird's mouth" detail for the low-end bearing. Web fillers are required for I-joists seated in hangers that do not laterally support the top flange or for hangers that require nailing into the web.
2. L/240 represents the maximum deflection allowed per code for roof joists supporting non-plaster ceilings. Verify deflection limits with local code requirements.
3. Roof joists shall have a minimum pitch of 1/4" per foot (1/4:12) for positive drainage.
4. Roof applications in high wind areas require special analysis which may reduce spans and may require bracing of the bottom flange and special connectors to resist uplift.
5. For conditions not shown, use the Uniform Roof Load (PLF) tables, LP's design software or contact your LP® SolidStart® Engineered Wood Products distributor for assistance.

	Series	Depth	16" oc		19.2" oc		24" oc			
			Roof Dead Load →		15 psf	20 psf	15 psf	20 psf	15 psf	20 psf
ROOF LIVE LOAD	40 psf 115% Snow	LPI 36	11'-7/8"	21'-10"	21'-0"	20'-6"	19'-8"	18'-11"	17'-6"	
			14"	24'-8"	23'-9"	23'-2"	22'-0"	19'-7"	17'-6"	
			16"	27'-3"	26'-3"	24'-7"	22'-1"	19'-8"	17'-7"	
			18"	29'-9"	28'-7"	27'-3"	24'-5"	21'-9"	19'-5"	
		LPI 42Plus	11'-7/8"	23'-8"	22'-9"	22'-3"	21'-5"	20'-7"	19'-9"	
			14"	26'-11"	25'-11"	25'-3"	24'-4"	23'-5"	22'-2"	
	16"		29'-10"	28'-9"	28'-0"	27'-0"	25'-7"	22'-11"		
	18"		32'-0"	30'-9"	30'-0"	28'-11"	27'-10"	24'-11"		
	LPI 52Plus	11'-7/8"	24'-5"	23'-7"	23'-0"	22'-1"	21'-3"	20'-6"		
		14"	27'-9"	26'-9"	26'-1"	25'-1"	24'-2"	23'-3"		
		16"	30'-9"	29'-7"	28'-10"	27'-10"	26'-9"	24'-4"		
		18"	34'-7"	33'-4"	32'-6"	31'-3"	27'-10"	24'-11"		
LPI 56	11'-7/8"	25'-4"	24'-4"	23'-9"	22'-10"	21'-11"	19'-8"			
	14"	28'-8"	27'-7"	26'-11"	24'-8"	22'-0"	19'-8"			
	16"	31'-8"	29'-9"	27'-7"	24'-9"	22'-0"	19'-9"			
	18"	34'-6"	32'-11"	30'-7"	27'-4"	24'-4"	21'-10"			
50 psf 115% Snow	LPI 36	11'-7/8"	20'-8"	20'-0"	19'-5"	18'-9"	16'-9"	15'-2"		
		14"	23'-5"	22'-8"	21'-1"	19'-1"	16'-9"	15'-3"		
		16"	25'-5"	23'-1"	21'-2"	19'-2"	16'-10"	15'-4"		
		18"	28'-2"	25'-7"	23'-5"	21'-3"	18'-8"	16'-11"		
	LPI 42Plus	11'-7/8"	22'-5"	21'-9"	21'-1"	20'-5"	19'-6"	18'-7"		
		14"	25'-6"	24'-9"	24'-0"	23'-2"	21'-3"	19'-11"		
		16"	28'-4"	27'-5"	26'-7"	25'-0"	21'-11"	19'-11"		
		18"	30'-4"	29'-5"	28'-6"	27'-2"	23'-11"	21'-8"		
	LPI 52Plus	11'-7/8"	23'-3"	22'-6"	21'-10"	21'-1"	20'-2"	19'-6"		
		14"	26'-4"	25'-6"	24'-9"	23'-11"	22'-10"	20'-9"		
		16"	29'-2"	28'-3"	27'-5"	26'-6"	23'-4"	21'-2"		
		18"	31'-6"	28'-8"	26'-2"	23'-10"	20'-11"	19'-0"		
LPI 56	11'-7/8"	24'-0"	23'-3"	22'-6"	21'-5"	18'-10"	17'-1"			
	14"	27'-2"	25'-10"	23'-8"	21'-6"	18'-10"	17'-2"			
	16"	28'-6"	25'-11"	23'-8"	21'-6"	18'-11"	17'-2"			
	18"	31'-6"	28'-8"	26'-2"	23'-10"	20'-11"	19'-0"			
60 psf 115% Snow	LPI 36	11'-7/8"	19'-9"	19'-2"	18'-4"	16'-11"	14'-8"	13'-5"		
		14"	22'-2"	20'-4"	18'-5"	16'-11"	14'-8"	13'-6"		
		16"	22'-3"	20'-5"	18'-6"	17'-0"	14'-9"	13'-7"		
		18"	24'-7"	22'-7"	20'-6"	18'-10"	16'-4"	15'-0"		
	LPI 42Plus	11'-7/8"	21'-5"	20'-10"	20'-2"	19'-7"	17'-11"	16'-5"		
		14"	24'-5"	23'-9"	22'-11"	21'-5"	18'-7"	17'-1"		
		16"	27'-1"	26'-4"	24'-1"	22'-2"	19'-3"	17'-8"		
		18"	29'-0"	28'-2"	26'-3"	24'-1"	20'-11"	19'-2"		
	LPI 52Plus	11'-7/8"	22'-2"	21'-7"	20'-10"	20'-3"	19'-3"	18'-0"		
		14"	25'-2"	24'-6"	23'-8"	23'-0"	20'-0"	18'-5"		
		16"	27'-11"	27'-1"	25'-7"	23'-6"	20'-5"	18'-9"		
		18"	29'-0"	28'-0"	26'-3"	24'-1"	20'-11"	19'-2"		
LPI 56	11'-7/8"	22'-11"	22'-3"	20'-8"	19'-0"	16'-6"	15'-2"			
	14"	24'-11"	22'-11"	20'-9"	19'-0"	16'-6"	15'-2"			
	16"	24'-11"	22'-11"	20'-9"	19'-1"	16'-7"	15'-2"			
	18"	27'-7"	25'-4"	22'-11"	21'-1"	18'-3"	16'-10"			
		24"	28'-2"	25'-10"	23'-5"	21'-6"	18'-8"	17'-1"		

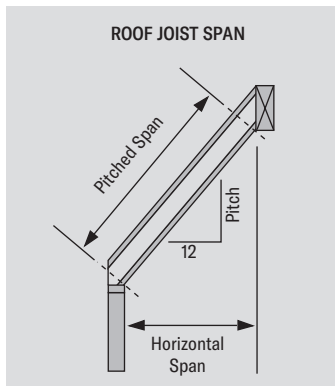

ACTUAL DEFLECTION BASED ON SPAN AND LIMIT			
Span (ft)	L/360	L/240	L/180
10'	5/16"	1/2"	11/16"
12'	3/8"	5/8"	13/16"
14'	7/16"	11/16"	15/16"
16'	9/16"	13/16"	1-1/16"
18'	5/8"	7/8"	1-3/16"
20'	11/16"	1"	1-5/16"
22'	3/4"	1-1/8"	1-7/16"
24'	13/16"	1-3/16"	1-5/8"
26'	7/8"	1-5/16"	1-3/4"
28'	15/16"	1-3/8"	1-7/8"
30'	1"	1-1/2"	2"

* Deflections rounded to the nearest 1/16".

Uniform Roof Load (PLF) Tables: LPI 36 Simple Spans

TO USE:

- Select the span required. For roofs with a pitch of 2:12 or greater, the horizontal span shall be multiplied by the appropriate roof pitch adjustment factor from the table at the bottom of this page.
- Compare the design total load to the appropriate Total Load column for Snow (115%) or Non-Snow (125%). Where two numbers are shown, the first number represents the Total Load capacity without web stiffeners. The second number represents the Total Load capacity with stiffeners. (See Additional Notes below.)
- Compare the design live load to the appropriate Live Load column (L/360 or L/240). For live load deflection limits of L/600 or L/480, compare the design live load to the appropriate Live Load column from the Uniform Floor Load Tables on pages 6-13.
- Select a product that exceeds both the design total and live loads.
- Specify web stiffeners as dictated by the Total Load column.

EXAMPLE:

An I-Joist has the horizontal clear span of 32'-3", supporting 30 psf Snow Load (115%) and 15 psf Dead Load, spaced 24" oc, with a slope of 4:12. Select a joist that satisfies an L/240 live load deflection limit.

- Sloped Span = $(27' + 3 \cdot 1/2'') \cdot 1.054 = 28.86'$
Select the row corresponding to a 29' span.
- Design Total Load = $(30 + 15) \cdot (24 / 12) = 90$ plf
Design Live Load = $30 \cdot (24 / 12) = 60$ plf
- Select the first I-Joist to exceed both Total Load for Snow (115%) and L/240:

The 16" LPI 36 supports 93 plf Total Load (Snow 115%) and 70 plf Live Load at L/240

NOTE: Web stiffeners required at both end supports.

Span (ft)	11-7/8" LPI 36				14" LPI 36				16" LPI 36				Span (ft)
	Live Load		Total Load		Live Load		Total Load		Live Load		Total Load		
	L/360	L/240	Snow 115%	Non-Snow 125%	L/360	L/240	Snow 115%	Non-Snow 125%	L/360	L/240	Snow 115%	Non-Snow 125%	
12'			196 / 260	213 / 260			197 / 260	214 / 260			198 / 260	215 / 260	12'
13'	226		182 / 240	197 / 240			182 / 240	198 / 240			183 / 240	199 / 240	13'
14'	186		169 / 223	184 / 223			169 / 223	184 / 223			170 / 223	185 / 223	14'
15'	155		158 / 209	171 / 209			158 / 209	172 / 209			159 / 209	173 / 209	15'
16'	130	195	148 / 196	161 / 196	183		148 / 196	161 / 196			149 / 196	162 / 196	16'
17'	110	166	139 / 184	152 / 184	156		140 / 184	152 / 184			140 / 184	153 / 184	17'
18'	94	141	132 / 174	143 / 174	133		132 / 174	144 / 174			133 / 174	144 / 174	18'
19'	81	122	125 / 161	136 / 163	115		125 / 165	136 / 165	151		126 / 165	137 / 165	19'
20'	70	105	119 / 141	129 / 141	100	150	119 / 157	129 / 157	132		120 / 157	130 / 157	20'
21'	61	92	113 / 123	123	87	131	113 / 150	123 / 150	115		114 / 150	124 / 150	21'
22'	54	81	108	108	76	115	108 / 143	118 / 143	101		109 / 143	118 / 143	22'
23'	47	71	95	95	67	101	104 / 133	113 / 135	89	134	104 / 137	113 / 137	23'
24'	42	63	84	84	60	90	99 / 120	108 / 120	79	119	100 / 131	108 / 131	24'
25'	37	56	75	75	53	80	95 / 107	104 / 107	71	106	96 / 126	104 / 126	25'
26'	33	50	67	67	48	72	92 / 96	96	63	95	92 / 121	100 / 121	26'
27'	30	45	60	60	43	64	86	86	57	85	89 / 112	97 / 114	27'
28'	27	40	54	54	38	58	77	77	51	77	86 / 103	93 / 103	28'
29'	24	36	48	48	35	52	70	70	46	70	83 / 93	90 / 93	29'
30'	22	33	44	44	31	47	63	63	42	63	80 / 84	84	30'
31'	20	30	40	40	28	43	57	57	38	57	77	77	31'
32'	18	27	36	36	26	39	52	52	35	52	70	70	32'
33'	16	25	33	33	24	36	48	48	32	48	64	64	33'
34'	15	23	30	30	22	33	44	44	29	44	59	59	34'
35'	14	21	28	28	20	30	40	40	27	40	54	54	35'
36'	-	-	-	-	18	28	37	37	25	37	50	50	36'
37'	-	-	-	-	17	26	34	34	23	34	46	46	37'
38'	-	-	-	-	16	24	32	32	21	32	42	42	38'

Span (ft)	18" LPI 36				Span (ft)
	Live Load		Total Load		
	L/360	L/240	Snow 115%	Non-Snow 125%	
12'			217 / 333	236 / 362	12'
13'			201 / 308	218 / 335	13'
14'			187 / 287	203 / 312	14'
15'			175 / 268	190 / 291	15'
16'			164 / 252	178 / 274	16'
17'	255		155 / 237	168 / 258	17'
18'	219		146 / 224	159 / 244	18'
19'	190		139 / 213	151 / 231	19'
20'	166		132 / 202	143 / 220	20'
21'	145		126 / 193	137 / 210	21'
22'	128	192	120 / 184	131 / 200	22'
23'	113	170	115 / 173	125 / 188	23'
24'	101	151	110 / 159	120 / 172	24'
25'	90	135	106 / 146	115 / 159	25'
26'	80	121	102 / 135	111 / 147	26'
27'	72	109	98 / 125	107 / 136	27'
28'	65	98	95 / 117	103 / 127	28'
29'	59	89	91 / 109	99 / 118	29'
30'	54	81	88 / 102	96 / 108	30'
31'	49	73	86 / 95	93 / 98	31'
32'	44	67	83 / 89	89	32'
33'	41	61	80 / 82	82	33'
34'	37	56	75	75	34'
35'	34	52	69	69	35'
36'	32	48	64	64	36'
37'	29	44	59	59	37'
38'	27	41	54	54	38'

DESIGN ASSUMPTIONS:

- Span is the clear distance between supports, along the sloped length of the joist, for simple span applications only.
- The values in the tables are for uniform loads only and represent the design gravity loads, unadjusted for roof pitch. Wind uplift has not been considered.
- Total Load is for Snow (115%) or Non-Snow (125%) duration as noted.
- These tables do not reflect any additional stiffness provided by the roof sheathing.
- Total deflection is limited to L/180. Long term deflection (creep) has not been considered.
- Live Load deflection is limited to L/360 or L/240 as noted in the table.
- These tables assume full lateral support of the compression flange (maximum unbraced length of 24"). Design for wind may require bracing of the bottom flange and special connectors to resist uplift.
- The spans are based on an end bearing length of at least 1-3/4" for depths up to 16" and at least 2-1/2" for depths greater than 16", and are limited to the bearing capacity for an SPF wall plate ($F_{CL} = 425$ psi).

ADDITIONAL NOTES:

- The allowable loads represent the capacity of the joist in pounds per lineal foot (plf) of length.
- The designer shall check the appropriate Total Load and the Live Load column.
- For roofs with a pitch of 2:12 or greater, the horizontal span shall be multiplied by the appropriate adjustment factor from the table at the bottom of this page.
- To design a double I-Joist, the values in these tables can be doubled, or the design loads on the I-Joist may be halved to verify the capacity of each ply. The capacity is additive.
- Web stiffeners are not required where only one value is shown for Total Load or when the design total load does not exceed the first value (capacity without stiffeners) in the Total Load column where two values are given. Web stiffeners are required at both end supports if the design total load exceeds the first value. Do not exceed the second value (capacity with stiffeners).
- Web fillers are required for I-Joists seated in hangers that do not laterally support the top flange or for hangers that require nailing into the web.
- Where the Live Load is blank, the Total Load governs the design.
- To design for a live load deflection limit of L/600 or L/480, use the Uniform Floor Load tables.
- Do not use a product where designated "-" without further analysis by a design professional.

ROOF PITCH ADJUSTMENT FACTORS

Roof Pitch	2:12	3:12	4:12	5:12	6:12	7:12	8:12	9:12	10:12	11:12	12:12
Factor	1.014	1.031	1.054	1.083	1.118	1.158	1.202	1.250	1.302	1.357	1.414

Uniform Roof Load (PLF) Tables: LPI 36 Continuous Spans

TO USE:

- Select the span required. For roofs with a pitch of 2:12 or greater, the horizontal span shall be multiplied by the appropriate roof pitch adjustment factor from the table at the bottom of this page.
- Compare the design total load to the appropriate Total Load column for Snow (115%) or Non-Snow (125%). Where two numbers are shown, the first number represents the Total Load capacity without web stiffeners. The second number represents the Total Load capacity with stiffeners. (See Additional Notes below.)
- Compare the design live load to the appropriate Live Load column (L/360 or L/240). For live load deflection limits of L/600 or L/480, compare the design live load to the appropriate Live Load column from the Uniform Floor Load Tables on pages 6-13.
- Select a product that exceeds both the design total and live loads.
- Specify web stiffeners as dictated by the Total Load column.

EXAMPLE:

An I-Joist has the horizontal clear span of 20'-8" and 32'-3", supporting 30 psf Snow Load (115%) and 15 psf Dead Load, spaced 24" oc, with a slope of 4:12. Select a joist that satisfies an L/240 live load deflection limit.

- Sloped Span = $(32 + 3/12) * 1.054 = 33.99'$ (use the longest span)
Select the row corresponding to a 34' span.
- Design Total Load = $(30 + 15) * (24 / 12) = 90$ plf
Design Live Load = $30 * (24 / 12) = 60$ plf
- Select the first I-Joist to exceed both Total Load for Snow (115%) and L/240:
Cannot use the LPI 36 series - exceeds Total Load for all depths at 34' (plate bearing control)

Span (ft)	11-7/8" LPI 36				14" LPI 36				16" LPI 36				Span (ft)
	Live Load		Total Load		Live Load		Total Load		Live Load		Total Load		
	L/360	L/240	Snow 115%	Non-Snow 125%	L/360	L/240	Snow 115%	Non-Snow 125%	L/360	L/240	Snow 115%	Non-Snow 125%	
12'			187 / 208	203 / 208			187 / 208	203 / 208			187 / 208	203 / 208	12'
13'			173 / 192	188 / 192			173 / 192	188 / 192			173 / 192	188 / 192	13'
14'			160 / 179	174 / 179			160 / 179	174 / 179			160 / 179	174 / 179	14'
15'			150 / 167	163 / 167			150 / 167	163 / 167			150 / 167	163 / 167	15'
16'			141 / 157	153 / 157			141 / 157	153 / 157			141 / 157	153 / 157	16'
17'	142		133 / 147	144 / 147			133 / 147	144 / 147			133 / 147	144 / 147	17'
18'	122		125 / 139	136 / 139			125 / 139	136 / 139			125 / 139	136 / 139	18'
19'	105		119 / 132	129 / 132			119 / 132	129 / 132			119 / 132	129 / 132	19'
20'	91		113 / 126	123 / 126			113 / 126	123 / 126			113 / 126	123 / 126	20'
21'	79	119	108 / 120	117 / 120	113		108 / 120	117 / 120			108 / 120	117 / 120	21'
22'	70	105	103 / 114	112	99		103 / 114	112 / 114			103 / 114	112 / 114	22'
23'	61	92	98	107	88		98 / 109	107 / 109			98 / 109	107 / 109	23'
24'	54	82	94	102	78		94 / 105	102 / 105	103		94 / 105	102 / 105	24'
25'	48	73	90	97	69		90 / 101	98 / 101	92		90 / 101	98 / 101	25'
26'	43	65	86	87	62	93	87 / 97	95	82		87 / 97	95 / 97	26'
27'	39	58	78	78	56	84	84	91	74		84 / 93	91 / 93	27'
28'	35	52	70	70	50	75	81	88	67		81 / 90	88 / 90	28'
29'	31	47	63	63	45	68	78	85	60		78 / 87	85 / 87	29'
30'	28	43	57	57	41	62	75	82	55	82	75 / 84	82	30'
31'	26	39	52	52	37	56	73	75	50	75	73 / 81	79	31'
32'	23	35	47	47	34	51	68	68	45	68	71	77	32'
33'	21	32	43	43	31	47	63	63	42	63	69	75	33'
34'	20	30	40	40	28	43	57	57	38	57	67	72	34'
35'	18	27	36	36	26	39	53	53	35	53	65	70	35'
36'	-	-	-	-	24	36	49	49	32	49	63	65	36'
37'	-	-	-	-	22	33	45	45	30	45	59	60	37'
38'	-	-	-	-	20	31	41	41	27	41	55	55	38'

Span (ft)	18" LPI 36				Span (ft)
	Live Load		Total Load		
	L/360	L/240	Snow 115%	Non-Snow 125%	
12'			186 / 207	202 / 207	12'
13'			172 / 191	187 / 191	13'
14'			160 / 178	174 / 178	14'
15'			149 / 166	162 / 166	15'
16'			140 / 156	152 / 156	16'
17'			132 / 147	144 / 147	17'
18'			125 / 139	136 / 139	18'
19'			118 / 132	129 / 132	19'
20'			112 / 125	122 / 125	20'
21'			107 / 119	117 / 119	21'
22'			102 / 114	111 / 114	22'
23'			98 / 109	107 / 109	23'
24'			94 / 105	102 / 105	24'
25'			90 / 100	98 / 100	25'
26'			87 / 97	94 / 97	26'
27'			84 / 93	91 / 93	27'
28'	85		81 / 90	88 / 90	28'
29'	77		78 / 87	85 / 87	29'
30'	70		75 / 84	82 / 84	30'
31'	64		73 / 81	79 / 81	31'
32'	58		71 / 79	77 / 79	32'
33'	53		68 / 76	74 / 76	33'
34'	49	74	66 / 74	72 / 74	34'
35'	45	68	65 / 72	70	35'
36'	41	62	63	68	36'
37'	38	58	61	66	37'
38'	35	53	59	65	38'

DESIGN ASSUMPTIONS:

- Span is the clear distance between supports, along the sloped length of the joist, for continuous span applications only. Continuous spans are based on the longest span. The shortest span shall not be less than 50% of the longest span.
- The values in the tables are for uniform loads only and represent the design gravity loads, unadjusted for roof pitch. Wind uplift has not been considered.
- Total Load is for Snow (115%) or Non-Snow (125%) duration as noted.
- These tables do not reflect any additional stiffness provided by the roof sheathing.
- Total deflection is limited to L/180. Long term deflection (creep) has not been considered.
- Live Load deflection is limited to L/360 or L/240 as noted in the table.
- These tables assume full lateral support of the compression flange (maximum unbraced length of 24'). Design for wind may require bracing of the bottom flange and special connectors to resist uplift.
- The spans are based on an end bearing length of at least 1-3/4" for depths up to 16" and at least 2-1/2" for depths greater than 16"; an intermediate bearing length of at least 3-1/2" and are limited to the bearing capacity for an SPF wall plate ($F_{cL} = 425$ psi).

ROOF PITCH ADJUSTMENT FACTORS											
Roof Pitch	2:12	3:12	4:12	5:12	6:12	7:12	8:12	9:12	10:12	11:12	12:12
Factor	1.014	1.031	1.054	1.083	1.118	1.158	1.202	1.250	1.302	1.357	1.414

ADDITIONAL NOTES:

- The allowable loads represent the capacity of the joist in pounds per lineal foot (plf) of length.
- The designer shall check the appropriate Total Load and the Live Load column.
- For roofs with a pitch of 2:12 or greater, the horizontal span shall be multiplied by the appropriate adjustment factor from the table at the bottom of this page.
- To design a double I-Joist, the values in these tables can be doubled, or the design loads on the I-Joist may be halved to verify the capacity of each ply. The capacity is additive.
- Web stiffeners are not required where only one value is shown for Total Load or when the design total load does not exceed the first value (capacity without stiffeners) in the Total Load column where two values are given. Web stiffeners are required at interior supports if the design total load exceeds the first value. Do not exceed the second value (capacity with stiffeners). If the capacity with stiffeners is marked "**", then web stiffeners are also required at both end supports.
- Web fillers are required for I-Joists seated in hangers that do not laterally support the top flange or for hangers that require nailing into the web.
- Where the Live Load is blank, the Total Load governs the design.
- To design for a live load deflection limit of L/600 or L/480, use the Uniform Floor Load tables.
- Do not use a product where designated "-" without further analysis by a design professional.

Uniform Roof Load (PLF) Tables: LPI 42Plus Simple Spans

TO USE:

- Select the span required. For roofs with a pitch of 2:12 or greater, the horizontal span shall be multiplied by the appropriate roof pitch adjustment factor from the table at the bottom of this page.
- Compare the design total load to the appropriate Total Load column for Snow (115%) or Non-Snow (125%). Where two numbers are shown, the first number represents the Total Load capacity without web stiffeners. The second number represents the Total Load capacity with stiffeners. (See Additional Notes below.)
- Compare the design live load to the appropriate Live Load column (L/360 or L/240). For live load deflection limits of L/600 or L/480, compare the design live load to the appropriate Live Load column from the Uniform Floor Load Tables on pages 6-13.
- Select a product that exceeds both the design total and live loads.
- Specify web stiffeners as dictated by the Total Load column.

EXAMPLE:

An I-Joist has the horizontal clear span of 32'-3", supporting 30 psf Snow Load (115%) and 15 psf Dead Load, spaced 24" oc, with a slope of 4:12. Select a joist that satisfies an L/240 live load deflection limit.

- Sloped Span = $(32 + 3/12) * 1.054 = 33.99'$
Select the row corresponding to a 34' span.
- Design Total Load = $(30 + 15) * (24 / 12) = 90$ plf
Design Live Load = $30 * (24 / 12) = 60$ plf
- Select the first I-Joist to exceed both Total Load for Snow (115%) and L/240.

The 20" LPI 42Plus supports 95 plf Total Load (Snow 115%) and 88 plf Live Load at L/240

Span (ft)	11-7/8" LPI 42Plus				14" LPI 42Plus				16" LPI 42Plus				Span (ft)
	Live Load		Total Load		Live Load		Total Load		Live Load		Total Load		
	L/360	L/240	Snow 115%	Non-Snow 125%	L/360	L/240	Snow 115%	Non-Snow 125%	L/360	L/240	Snow 115%	Non-Snow 125%	
12'			239 / 284	260 / 309			248 / 314	270 / 342			257 / 342	279 / 372	12'
13'	280		221 / 263	240 / 286			230 / 291	250 / 316			237 / 317	258 / 344	13'
14'	231		205 / 244	223 / 266			214 / 270	232 / 294			221 / 294	240 / 320	14'
15'	193		192 / 228	209 / 248	272		200 / 252	217 / 274			206 / 275	224 / 299	15'
16'	163		180 / 214	196 / 233	230		187 / 237	204 / 258			194 / 258	210 / 281	16'
17'	138	207	170 / 202	185 / 220	196		176 / 223	192 / 243	259		182 / 243	198 / 264	17'
18'	118	177	160 / 191	174 / 208	168		167 / 211	181 / 229	223		172 / 230	187 / 250	18'
19'	102	153	152 / 174	165 / 190	145		158 / 200	172 / 217	193		163 / 218	178 / 237	19'
20'	88	133	145 / 157	157 / 171	126	190	150 / 190	163 / 206	168		155 / 207	169 / 225	20'
21'	77	116	138 / 143	150 / 155	111	166	143 / 172	156 / 187	147		148 / 197	161 / 215	21'
22'	68	102	130	136	97	146	137 / 157	149 / 171	130	195	141 / 182	154 / 198	22'
23'	60	90	119	120	86	129	131 / 144	142 / 156	115	173	135 / 167	147 / 181	23'
24'	53	79	106	106	76	115	125 / 132	136 / 143	102	153	130 / 153	141 / 166	24'
25'	47	71	94	94	68	102	120 / 122	131 / 132	91	137	125 / 141	135 / 153	25'
26'	42	63	84	84	61	91	112	122	82	123	120 / 130	130 / 142	26'
27'	38	57	76	76	55	82	104	110	73	110	115 / 121	125 / 131	27'
28'	34	51	68	68	49	74	97	99	66	99	111 / 112	121 / 122	28'
29'	31	46	62	62	44	67	89	89	60	90	105	114	29'
30'	28	42	56	56	40	61	81	81	54	82	98	107	30'
31'	25	38	51	51	37	55	74	74	49	74	92	99	31'
32'	23	34	46	46	33	50	67	67	45	68	86	91	32'
33'	21	32	42	42	30	46	61	61	41	62	81	83	33'
34'	19	29	39	39	28	42	56	56	38	57	76	76	34'
35'	17	26	35	35	26	39	52	52	35	52	70	70	35'
36'	16	24	33	33	24	36	48	48	32	48	65	65	36'
37'	15	22	30	30	22	33	44	44	30	45	60	60	37'
38'	14	21	28	28	20	30	41	41	27	41	55	55	38'

Span (ft)	18" LPI 42Plus				20" LPI 42Plus				24" LPI 42Plus				Span (ft)
	Live Load		Total Load		Live Load		Total Load		Live Load		Total Load		
	L/360	L/240	Snow 115%	Non-Snow 125%	L/360	L/240	Snow 115%	Non-Snow 125%	L/360	L/240	Snow 115%	Non-Snow 125%	
12'			277 / 426	302 / 464			277 / 453	302 / 493			277 / 501	302 / 544	12'
13'			257 / 395	279 / 429			257 / 420	279 / 456			257 / 463	279 / 504	13'
14'			239 / 367	260 / 399			239 / 390	260 / 424			239 / 431	260 / 469	14'
15'			223 / 343	243 / 373			223 / 365	243 / 397			223 / 403	243 / 438	15'
16'			210 / 322	228 / 351			210 / 343	228 / 373			210 / 378	228 / 411	16'
17'	320		198 / 304	215 / 330			198 / 323	215 / 351			198 / 357	215 / 388	17'
18'	275		187 / 287	203 / 312			187 / 305	203 / 332			187 / 337	203 / 367	18'
19'	238		177 / 273	193 / 296	296		177 / 290	193 / 315			177 / 320	193 / 348	19'
20'	207		168 / 247	183 / 269	258		168 / 274	183 / 298			168 / 304	183 / 331	20'
21'	182		161 / 224	175 / 244	226		161 / 248	175 / 270			161 / 290	175 / 315	21'
22'	160		153 / 205	167 / 223	199		153 / 227	167 / 246	290		153 / 270	167 / 293	22'
23'	141		147 / 187	160 / 204	176		147 / 207	160 / 225	258		147 / 247	160 / 268	23'
24'	125		141 / 172	153 / 187	157		141 / 191	153 / 207	230		141 / 227	153 / 247	24'
25'	112	168	135 / 159	147 / 173	140		135 / 176	147 / 191	205		135 / 209	147 / 227	25'
26'	100	150	130 / 147	141 / 160	126		130 / 163	141 / 177	184		130 / 193	141 / 210	26'
27'	90	135	125 / 136	136 / 148	113		125 / 151	136 / 164	166		125 / 179	136 / 195	27'
28'	81	122	121 / 127	131 / 138	102		121 / 140	131 / 152	150		121 / 167	131 / 181	28'
29'	73	110	117 / 118	127 / 128	92	139	117 / 131	127 / 142	136		117 / 156	127 / 169	29'
30'	67	100	110	120	84	126	113 / 122	123 / 133	124		113 / 145	123 / 158	30'
31'	61	91	103	112	76	115	109 / 114	119 / 124	113		109 / 136	119 / 148	31'
32'	55	83	97	106	70	105	106 / 107	115 / 117	103		106 / 128	115 / 139	32'
33'	51	76	91	99	64	96	101	110	94		103 / 120	112 / 131	33'
34'	46	70	86	93	58	88	95	103	87		100 / 113	108 / 123	34'
35'	43	64	81	86	54	81	90	98	80		97 / 107	105 / 116	35'
36'	39	59	77	79	49	74	85	92	74		94 / 101	102 / 110	36'
37'	36	55	73	73	46	69	80	87	68	102	92 / 96	100 / 104	37'
38'	33	50	67	67	42	64	76	83	63	95	89 / 91	97 / 99	38'

DESIGN ASSUMPTIONS:

- Span is the clear distance between supports, along the sloped length of the joist, for simple span applications only.
- The values in the tables are for uniform loads only and represent the design gravity loads, unadjusted for roof pitch. Wind uplift has not been considered.
- Total Load is for Snow (115%) or Non-Snow (125%) duration as noted.
- These tables do not reflect any additional stiffness provided by the roof sheathing.
- Total deflection is limited to L/180. Long term deflection (creep) has not been considered.
- Live Load deflection is limited to L/360 or L/240 as noted in the table.
- These tables assume full lateral support of the compression flange (maximum unbraced length of 24"). Design for wind may require bracing of the bottom flange and special connectors to resist uplift.
- The spans are based on an end bearing length of at least 1-3/4" for depths up to 16" and at least 2-1/2" for depths greater than 16", and are limited to the bearing capacity for an SPF wall plate ($F_{CL} = 425$ psi).

ADDITIONAL NOTES:

- The allowable loads represent the capacity of the joist in pounds per lineal foot (plf) of length.
- The designer shall check the appropriate Total Load and the Live Load column.
- For roofs with a pitch of 2:12 or greater, the horizontal span shall be multiplied by the appropriate adjustment factor from the table at the bottom of this page.
- To design a double I-Joist, the values in these tables can be doubled, or the design loads on the I-Joist may be halved to verify the capacity of each ply. The capacity is additive.
- Web stiffeners are not required where only one value is shown for Total Load or when the design total load does not exceed the first value (capacity without stiffeners) in the Total Load column where two values are given. Web stiffeners are required at both end supports if the design total load exceeds the first value. Do not exceed the second value (capacity with stiffeners).
- Web fillers are required for I-Joists seated in hangers that do not laterally support the top flange or for hangers that require nailing into the web.
- Where the Live Load is blank, the Total Load governs the design.
- To design for a live load deflection limit of L/600 or L/480, use the Uniform Floor Load tables.
- Do not use a product where designated "-" without further analysis by a design professional.

ROOF PITCH ADJUSTMENT FACTORS

Roof Pitch	2:12	3:12	4:12	5:12	6:12	7:12	8:12	9:12	10:12	11:12	12:12
Factor	1.014	1.031	1.054	1.083	1.118	1.158	1.202	1.250	1.302	1.357	1.414

Uniform Roof Load (PLF) Tables: LPI 42Plus Continuous Spans

TO USE:

- Select the span required. For roofs with a pitch of 2:12 or greater, the horizontal span shall be multiplied by the appropriate roof pitch adjustment factor from the table at the bottom of this page.
- Compare the design total load to the appropriate Total Load column for Snow (115%) or Non-Snow (125%). Where two numbers are shown, the first number represents the Total Load capacity without web stiffeners. The second number represents the Total Load capacity with stiffeners. (See Additional Notes below.)
- Compare the design live load to the appropriate Live Load column (L/360 or L/240). For live load deflection limits of L/600 or L/480, compare the design live load to the appropriate Live Load column from the Uniform Floor Load Tables on pages 6-13.
- Select a product that exceeds both the design total and live loads.
- Specify web stiffeners as dictated by the Total Load column.

EXAMPLE:

An I-Joist has the horizontal clear span of 20'-8" and 32'-3", supporting 30 psf Snow Load (115%) and 15 psf Dead Load, spaced 24" oc, with a slope of 4:12. Select a joist that satisfies an L/240 live load deflection limit.

- Sloped Span = $(32 + 3/12) * 1.054 = 33.99'$ (use the longest span)
Select the row corresponding to a 34' span.
- Design Total Load = $(30 + 15) * (24 / 12) = 90$ plf
Design Live Load = $30 * (24 / 12) = 60$ plf
- Select the first I-Joist to exceed both Total Load for Snow (115%) and L/240:

The 20" LPI 42Plus supports 92 plf Total Load (Snow 115%). Live Load does not control.

Span (ft)	11-7/8" LPI 42Plus				14" LPI 42Plus				16" LPI 42Plus				Span (ft)
	Live Load		Total Load		Live Load		Total Load		Live Load		Total Load		
	L/360	L/240	Snow 115%	Non-Snow 125%	L/360	L/240	Snow 115%	Non-Snow 125%	L/360	L/240	Snow 115%	Non-Snow 125%	
12'			226 / 244	246 / 265			235 / 266	255 / 290			242 / 282	264 / 307	12'
13'			209 / 226	227 / 245			217 / 246	236 / 268			224 / 261	244 / 284	13'
14'			194 / 210	211 / 228			202 / 229	219 / 249			208 / 243	227 / 264	14'
15'			181 / 196	197 / 213			188 / 214	205 / 233			195 / 227	212 / 246	15'
16'			170 / 184	185 / 200			177 / 201	192 / 218			183 / 213	199 / 231	16'
17'	178		160 / 173	174 / 188			167 / 189	181 / 206			172 / 200	187 / 218	17'
18'	153		152 / 164	165 / 178			157 / 179	171 / 194			163 / 189	177 / 206	18'
19'	132		144 / 155	156 / 169			149 / 170	162 / 184			154 / 180	168 / 195	19'
20'	114		137 / 147	149 / 160	163		142 / 161	154 / 175			147 / 171	159 / 186	20'
21'	100	150	130 / 140	142 / 153	143		135 / 154	147 / 167			140 / 163	152 / 177	21'
22'	88	132	124 / 129	135	126		129 / 147	140 / 159	168		133 / 155	145 / 169	22'
23'	77	116	118	129	111		124 / 140	134 / 153	149		128 / 149	139 / 162	23'
24'	69	103	109	118	99		118 / 131	129 / 143	132		122 / 142	133 / 155	24'
25'	61	92	100	109	88		114 / 121	124 / 131	118		118 / 137	128 / 149	25'
26'	55	82	93	101	79	119	109 / 112	119	106		113 / 130	123 / 141	26'
27'	49	74	86	94	71	107	104	113	95		109 / 120	118 / 131	27'
28'	44	66	80	87	64	96	96	105	86		105 / 112	114 / 122	28'
29'	40	60	75	80	58	87	90	98	78		101 / 104	110 / 113	29'
30'	36	54	70	73	52	79	84	91	71		97	106	30'
31'	33	49	65	66	48	72	79	86	64	97	91	99	31'
32'	30	45	60	60	44	66	74	80	59	89	86	93	32'
33'	27	41	55	55	40	60	69	76	54	81	81	88	33'
34'	25	38	51	51	37	55	65	71	49	74	76	83	34'
35'	23	35	46	46	34	51	62	67	45	68	72	78	35'
36'	21	32	43	43	31	47	58	62	42	63	68	74	36'
37'	19	29	39	39	28	43	55	57	39	58	64	70	37'
38'	18	27	36	36	26	40	52	53	36	54	61	66	38'

Span (ft)	18" LPI 42Plus				20" LPI 42Plus				24" LPI 42Plus				Span (ft)
	Live Load		Total Load		Live Load		Total Load		Live Load		Total Load		
	L/360	L/240	Snow 115%	Non-Snow 125%	L/360	L/240	Snow 115%	Non-Snow 125%	L/360	L/240	Snow 115%	Non-Snow 125%	
12'			256 / 313*	279 / 313*			256 / 313*	279 / 313*			256 / 313*	279 / 313*	12'
13'			237 / 289*	258 / 289*			237 / 289*	258 / 289*			237 / 289*	258 / 289*	13'
14'			221 / 269*	240 / 269*			221 / 269*	240 / 269*			221 / 269*	240 / 269*	14'
15'			206 / 251*	224 / 251*			206 / 251*	224 / 251*			206 / 251*	224 / 251*	15'
16'			194 / 236*	210 / 236*			194 / 236*	210 / 236*			194 / 236*	210 / 236*	16'
17'			182 / 222*	198 / 222*			182 / 222*	198 / 222*			182 / 222*	198 / 222*	17'
18'			172 / 210*	187 / 210*			172 / 210*	187 / 210*			172 / 210*	187 / 210*	18'
19'			163 / 199*	178 / 199*			163 / 199*	178 / 199*			163 / 199*	178 / 199*	19'
20'			155 / 190*	169 / 190*			155 / 190*	169 / 190*			155 / 190*	169 / 190*	20'
21'			148 / 181*	161 / 181*			148 / 181*	161 / 181*			148 / 181*	161 / 181*	21'
22'			141 / 173*	154 / 173*			141 / 173*	154 / 173*			141 / 173*	154 / 173*	22'
23'			135 / 165*	147 / 165*			135 / 165*	147 / 165*			135 / 165*	147 / 165*	23'
24'			130 / 158*	141 / 158*			130 / 158*	141 / 158*			130 / 158*	141 / 158*	24'
25'	146		125 / 152*	136 / 152*			125 / 152*	136 / 152*			125 / 152*	136 / 152*	25'
26'	131		120 / 146*	130 / 146*			120 / 146*	130 / 146*			120 / 146*	130 / 146*	26'
27'	117		116 / 136	126 / 141			116 / 141*	126 / 141*			116 / 141*	126 / 141*	27'
28'	106		111 / 126	121 / 136	133		111 / 136*	121 / 136*			111 / 136*	121 / 136*	28'
29'	96		108 / 118	117 / 131*	120		108 / 130*	117 / 131*			108 / 131*	117 / 131*	29'
30'	87		104 / 110	113 / 120	109		104 / 122	113 / 127			104 / 127*	113 / 127*	30'
31'	79		101 / 103	110 / 112	100		101 / 114	110 / 123			101 / 123*	110 / 123*	31'
32'	72		97	105	91		98 / 107	106 / 117			98 / 119*	106 / 119*	32'
33'	66		91	99	83		95 / 101	103 / 110			95 / 115*	103 / 115*	33'
34'	61	91	86	93	76		92 / 95	100 / 103			92 / 112*	100 / 112*	34'
35'	56	84	81	88	70		89 / 90	97	104		89 / 107	97 / 109	35'
36'	51	77	77	83	65		85	92	96		87 / 101	94 / 106	36'
37'	47	71	72	79	60		80	87	89		84 / 96	92 / 103	37'
38'	44	66	69	75	55		76	83	82		82 / 91	89 / 98	38'

DESIGN ASSUMPTIONS:

- Span is the clear distance between supports, along the sloped length of the joist, for continuous span applications only. Continuous spans are based on the longest span. The shortest span shall not be less than 50% of the longest span.
- The values in the tables are for uniform loads only and represent the design gravity loads, unadjusted for roof pitch. Wind uplift has not been considered.
- Total Load is for Snow (115%) or Non-Snow (125%) duration as noted.
- These tables do not reflect any additional stiffness provided by the roof sheathing.
- Total deflection is limited to L/180. Long term deflection (creep) has not been considered.
- Live Load deflection is limited to L/360 or L/240 as noted in the table.
- These tables assume full lateral support of the compression flange (maximum unbraced length of 24'). Design for wind may require bracing of the bottom flange and special connectors to resist uplift.
- The spans are based on an end bearing length of at least 1-3/4" for depths up to 16" and at least 2-1/2" for depths greater than 16"; an intermediate bearing length of at least 3-1/2" and are limited to the bearing capacity for an SPF wall plate ($F_{c\perp} = 425$ psi).

ADDITIONAL NOTES:

- The allowable loads represent the capacity of the joist in pounds per lineal foot (plf) of length.
- The designer shall check the appropriate Total Load and the Live Load column.
- For roofs with a pitch of 2:12 or greater, the horizontal span shall be multiplied by the appropriate adjustment factor from the table at the bottom of this page.
- To design a double I-Joist, the values in these tables can be doubled, or the design loads on the I-Joist may be halved to verify the capacity of each ply. The capacity is additive.
- Web stiffeners are not required where only one value is shown for Total Load or when the design total load does not exceed the first value (capacity without stiffeners) in the Total Load column where two values are given. Web stiffeners are required at interior supports if the design total load exceeds the first value. Do not exceed the second value (capacity with stiffeners). If the capacity with stiffeners is marked "*", then web stiffeners are also required at both end supports.
- Web fillers are required for I-Joists seated in hangers that do not laterally support the top flange or for hangers that require nailing into the web.
- Where the Live Load is blank, the Total Load governs the design.
- To design for a live load deflection limit of L/600 or L/480, use the Uniform Floor Load tables.
- Do not use a product where designated "-" without further analysis by a design professional.

ROOF PITCH ADJUSTMENT FACTORS

Roof Pitch	2:12	3:12	4:12	5:12	6:12	7:12	8:12	9:12	10:12	11:12	12:12
Factor	1.014	1.031	1.054	1.083	1.118	1.158	1.202	1.250	1.302	1.357	1.414

Uniform Roof Load (PLF) Tables: LPI 52Plus Simple Spans

TO USE:

- Select the span required. For roofs with a pitch of 2:12 or greater, the horizontal span shall be multiplied by the appropriate roof pitch adjustment factor from the table at the bottom of this page.
- Compare the design total load to the appropriate Total Load column for Snow (115%) or Non-Snow (125%). Where two numbers are shown, the first number represents the Total Load capacity without web stiffeners. The second number represents the Total Load capacity with stiffeners. (See Additional Notes below.)
- Compare the design live load to the appropriate Live Load column (L/360 or L/240). For live load deflection limits of L/600 or L/480, compare the design live load to the appropriate Live Load column from the Uniform Floor Load Tables on pages 6-13.
- Select a product that exceeds both the design total and live loads.
- Specify web stiffeners as dictated by the Total Load column.

EXAMPLE:

- An I-Joist has the horizontal clear span of 32'-3", supporting 20 psf Snow Load (115%) and 15 psf Dead Load, spaced 24" oc, with a slope of 4:12. Select a joist that satisfies an L/240 live load deflection limit.
- Sloped Span = $(32 + 3/12) * 1.054 = 33.99'$
Select the row corresponding to a 34' span.
 - Design Total Load = $(20 + 15) * (24 / 12) = 70$ plf
Design Live Load = $20 * (24 / 12) = 40$ plf
 - Select the first I-Joist to exceed both Total Load for Snow (115%) and L/240:
The 16" LPI 52Plus supports 83 plf Total Load (Snow 115%) and 62 plf Live Load at L/240

Span (ft)	11-7/8" LPI 52Plus				14" LPI 52Plus				16" LPI 52Plus				Span (ft)
	Live Load		Total Load		Live Load		Total Load		Live Load		Total Load		
	L/360	L/240	Snow 115%	Non-Snow 125%	L/360	L/240	Snow 115%	Non-Snow 125%	L/360	L/240	Snow 115%	Non-Snow 125%	
12'			262 / 345	285 / 375			267 / 375	291 / 393			273 / 393	296 / 393	12'
13'	314		242 / 319	263 / 346			247 / 347	269 / 363			252 / 363	274 / 363	13'
14'	259		225 / 296	245 / 322			230 / 322	250 / 338			234 / 338	255 / 338	14'
15'	216		210 / 277	229 / 301	303		215 / 301	233 / 316			219 / 316	238 / 316	15'
16'	181	272	197 / 260	215 / 282	256		202 / 283	219 / 296			205 / 296	223 / 296	16'
17'	154	231	186 / 245	202 / 266	218		190 / 266	206 / 279			194 / 279	210 / 279	17'
18'	131	197	176 / 231	191 / 252	187		179 / 252	195 / 264	247		183 / 264	199 / 264	18'
19'	113	170	167 / 212	181 / 227	161	242	170 / 239	185 / 250	213		173 / 250	189 / 250	19'
20'	98	147	158 / 192	172 / 196	140	210	162 / 227	176 / 238	186		165 / 238	179 / 238	20'
21'	85	128	151 / 171	164 / 171	122	184	154 / 209	168 / 227	162		157 / 227	171 / 227	21'
22'	75	113	144 / 150	150	107	161	147 / 191	160 / 208	143	215	150 / 216	163 / 216	22'
23'	66	99	132	132	95	142	141 / 175	153 / 190	126	190	144 / 203	156 / 207	23'
24'	58	88	117	117	84	126	135 / 161	147 / 168	112	168	138 / 186	150 / 199	24'
25'	52	78	104	104	75	112	130 / 148	141 / 150	100	150	132 / 172	144 / 187	25'
26'	46	70	93	93	67	100	125 / 134	134	89	134	127 / 159	138 / 173	26'
27'	42	63	84	84	60	90	120	120	80	121	122 / 147	133 / 160	27'
28'	37	56	75	75	54	81	108	108	72	109	118 / 137	128 / 145	28'
29'	34	51	68	68	49	73	98	98	65	98	114 / 128	124 / 131	29'
30'	31	46	62	62	44	67	89	89	59	89	110 / 119	119	30'
31'	28	42	56	56	40	61	81	81	54	81	107	109	31'
32'	25	38	51	51	37	55	74	74	49	74	99	99	32'
33'	23	35	47	47	33	50	67	67	45	68	91	91	33'
34'	21	32	43	43	31	46	62	62	41	62	83	83	34'
35'	19	29	39	39	28	42	57	57	38	57	76	76	35'
36'	18	27	36	36	26	39	52	52	35	53	70	70	36'
37'	16	25	33	33	24	36	48	48	32	49	65	65	37'
38'	15	23	31	31	22	33	45	45	30	45	60	60	38'

DESIGN ASSUMPTIONS:

- Span is the clear distance between supports, along the sloped length of the joist, for simple span applications only.
- The values in the tables are for uniform loads only and represent the design gravity loads, unadjusted for roof pitch. Wind uplift has not been considered.
- Total Load is for Snow (115%) or Non-Snow (125%) duration as noted.
- These tables do not reflect any additional stiffness provided by the roof sheathing.
- Total deflection is limited to L/180. Long term deflection (creep) has not been considered.
- Live Load deflection is limited to L/360 or L/240 as noted in the table.
- These tables assume full lateral support of the compression flange (maximum unbraced length of 24"). Design for wind may require bracing of the bottom flange and special connectors to resist uplift.
- The spans are based on an end bearing length of at least 1-3/4" for depths up to 16" and at least 2-1/2" for depths greater than 16", and are limited to the bearing capacity for an SPF wall plate ($F_{c\perp} = 425$ psi).

ADDITIONAL NOTES:

- The allowable loads represent the capacity of the joist in pounds per lineal foot (plf) of length.
- The designer shall check the appropriate Total Load and the Live Load column.
- For roofs with a pitch of 2:12 or greater, the horizontal span shall be multiplied by the appropriate adjustment factor from the table at the bottom of this page.
- To design a double I-Joist, the values in these tables can be doubled, or the design loads on the I-Joist may be halved to verify the capacity of each ply. The capacity is additive.
- Web stiffeners are not required where only one value is shown for Total Load or when the design total load does not exceed the first value (capacity without stiffeners) in the Total Load column where two values are given. Web stiffeners are required at both end supports if the design total load exceeds the first value. Do not exceed the second value (capacity with stiffeners).
- Web fillers are required for I-Joists seated in hangers that do not laterally support the top flange or for hangers that require nailing into the web.
- Where the Live Load is blank, the Total Load governs the design.
- To design for a live load deflection limit of L/600 or L/480, use the Uniform Floor Load tables.
- Do not use a product where designated "-" without further analysis by a design professional.

ROOF PITCH ADJUSTMENT FACTORS

Roof Pitch	2:12	3:12	4:12	5:12	6:12	7:12	8:12	9:12	10:12	11:12	12:12
Factor	1.014	1.031	1.054	1.083	1.118	1.158	1.202	1.250	1.302	1.357	1.414

Uniform Roof Load (PLF) Tables: LPI 52Plus Continuous Spans

TO USE:

- Select the span required. For roofs with a pitch of 2:12 or greater, the horizontal span shall be multiplied by the appropriate roof pitch adjustment factor from the table at the bottom of this page.
- Compare the design total load to the appropriate Total Load column for Snow (115%) or Non-Snow (125%). Where two numbers are shown, the first number represents the Total Load capacity without web stiffeners. The second number represents the Total Load capacity with stiffeners. (See Additional Notes below.)
- Compare the design live load to the appropriate Live Load column (L/360 or L/240). For live load deflection limits of L/600 or L/480, compare the design live load to the appropriate Live Load column from the Uniform Floor Load Tables on pages 6-13.
- Select a product that exceeds both the design total and live loads.
- Specify web stiffeners as dictated by the Total Load column.

EXAMPLE:

An I-Joist has the horizontal clear span of 20'-8" and 32'-3" supporting 30 psf Snow Load (115%) and 15 psf Dead Load, spaced 24" oc, with a slope of 4:12. Select a joist that satisfies an L/240 live load deflection limit.

- Sloped Span = $(32 + 3/12) * 1.054 = 33.99'$ (use the longest span)
Select the row corresponding to a 34' span.
- Design Total Load = $(30 + 15) * (24 / 12) = 90$ plf
Design Live Load = $30 * (24 / 12) = 60$ plf
- Select the first I-Joist to exceed both Total Load for Snow (115%) and L/240:
The 16" LPI 52Plus supports 92 plf Total Load (Snow 115%) and 81 plf Live Load at L/240

Span (ft)	11-7/8" LPI 52Plus				14" LPI 52Plus				16" LPI 52Plus				Span (ft)
	Live Load		Total Load		Live Load		Total Load		Live Load		Total Load		
	L/360	L/240	Snow 115%	Non-Snow 125%	L/360	L/240	Snow 115%	Non-Snow 125%	L/360	L/240	Snow 115%	Non-Snow 125%	
12'			255 / 299*	278 / 314*			257 / 314*	279 / 314*			258 / 314*	280 / 314*	12'
13'			236 / 276*	257 / 290*			237 / 290*	258 / 290*			238 / 290*	259 / 290*	13'
14'			220 / 257*	239 / 270*			221 / 270*	240 / 270*			222 / 270*	241 / 270*	14'
15'			205 / 240*	223 / 252*			206 / 252*	224 / 252*			207 / 252*	225 / 252*	15'
16'	234		193 / 225*	209 / 237*			193 / 237*	210 / 237*			194 / 237*	211 / 237*	16'
17'	198		181 / 212*	197 / 223*			182 / 223*	198 / 223*			183 / 223*	199 / 223*	17'
18'	170		172 / 201*	186 / 211*			172 / 211*	187 / 211*			173 / 211*	188 / 211*	18'
19'	146		163 / 190*	177 / 200*			163 / 200*	178 / 200*			164 / 200*	178 / 200*	19'
20'	127		155 / 181*	168 / 190*	181		155 / 190*	169 / 190*			156 / 190*	170 / 190*	20'
21'	111	166	147 / 172*	160 / 181*	158		148 / 181*	161 / 181*			149 / 181*	162 / 181*	21'
22'	97	146	141 / 157*	153	139		141 / 173*	154 / 173*			142 / 173*	154 / 173*	22'
23'	86	129	135	146	123		135 / 166*	147 / 166*	164		136 / 166*	148 / 166*	23'
24'	76	114	129	140	109		130 / 159*	141 / 159*	145		130 / 159*	142 / 159*	24'
25'	68	102	122	133	97	146	124 / 147*	135 / 152*	130		125 / 152*	136 / 152*	25'
26'	60	91	113	121	87	131	120 / 136	130 / 147	116		120 / 147*	131 / 147*	26'
27'	54	81	105	109	78	117	115 / 126	125	104		116 / 141*	126 / 141*	27'
28'	49	73	97	98	70	106	111	121	94		112 / 136*	121 / 136*	28'
29'	44	66	89	89	64	96	107	117	85	128	108 / 127*	117 / 132*	29'
30'	40	60	80	80	58	87	102	111	77	116	104 / 119	113 / 127	30'
31'	36	55	73	73	52	79	96	104	70	106	101 / 111	110	31'
32'	33	50	67	67	48	72	90	96	64	97	98	106	32'
33'	30	45	61	61	44	66	85	88	59	89	95	103	33'
34'	28	42	56	56	40	60	80	81	54	81	92	100	34'
35'	25	38	51	51	37	55	74	74	50	75	87	95	35'
36'	23	35	47	47	34	51	68	68	46	69	83	90	36'
37'	21	32	43	43	31	47	63	63	42	64	78	85	37'
38'	20	30	40	40	29	44	58	58	39	59	74	79	38'

DESIGN ASSUMPTIONS:

- Span is the clear distance between supports, along the sloped length of the joist, for continuous span applications only. Continuous spans are based on the longest span. The shortest span shall not be less than 50% of the longest span.
- The values in the tables are for uniform loads only and represent the design gravity loads, unadjusted for roof pitch. Wind uplift has not been considered.
- Total Load is for Snow (115%) or Non-Snow (125%) duration as noted.
- These tables do not reflect any additional stiffness provided by the roof sheathing.
- Total deflection is limited to L/180. Long term deflection (creep) has not been considered.
- Live Load deflection is limited to L/360 or L/240 as noted in the table.
- These tables assume full lateral support of the compression flange (maximum unbraced length of 24"). Design for wind may require bracing of the bottom flange and special connectors to resist uplift.
- The spans are based on an end bearing length of at least 1-3/4" for depths up to 16" and at least 2-1/2" for depths greater than 16"; an intermediate bearing length of at least 3-1/2" and are limited to the bearing capacity for an SPF wall plate ($F_{CL} = 425$ psi).

ADDITIONAL NOTES:

- The allowable loads represent the capacity of the joist in pounds per lineal foot (plf) of length.
- The designer shall check the appropriate Total Load and the Live Load column.
- For roofs with a pitch of 2:12 or greater, the horizontal span shall be multiplied by the appropriate adjustment factor from the table at the bottom of this page.
- To design a double I-Joist, the values in these tables can be doubled, or the design loads on the I-Joist may be halved to verify the capacity of each ply. The capacity is additive.
- Web stiffeners are not required where only one value is shown for Total Load or when the design total load does not exceed the first value (capacity without stiffeners) in the Total Load column where two values are given. Web stiffeners are required at interior supports if the design total load exceeds the first value. Do not exceed the second value (capacity with stiffeners). If the capacity with stiffeners is marked "", then web stiffeners are also required at both end supports.
- Web fillers are required for I-Joists seated in hangers that do not laterally support the top flange or for hangers that require nailing into the web.
- Where the Live Load is blank, the Total Load governs the design.
- To design for a live load deflection limit of L/600 or L/480, use the Uniform Floor Load tables.
- Do not use a product where designated "-" without further analysis by a design professional.

ROOF PITCH ADJUSTMENT FACTORS

Roof Pitch	2:12	3:12	4:12	5:12	6:12	7:12	8:12	9:12	10:12	11:12	12:12
Factor	1.014	1.031	1.054	1.083	1.118	1.158	1.202	1.250	1.302	1.357	1.414

Uniform Roof Load (PLF) Tables: LPI 56 Simple Spans

TO USE:

- Select the span required. For roofs with a pitch of 2:12 or greater, the horizontal span shall be multiplied by the appropriate roof pitch adjustment factor from the table at the bottom of this page.
- Compare the design total load to the appropriate Total Load column for Snow (115%) or Non-Snow (125%). Where two numbers are shown, the first number represents the Total Load capacity without web stiffeners. The second number represents the Total Load capacity with stiffeners. (See Additional Notes below.)
- Compare the design live load to the appropriate Live Load column (L/360 or L/240). For live load deflection limits of L/600 or L/480, compare the design live load to the appropriate Live Load column from the Uniform Floor Load Tables on pages 6-13.
- Select a product that exceeds both the design total and live loads.
- Specify web stiffeners as dictated by the Total Load column.

EXAMPLE:

An I-Joist has the horizontal clear span of 32'-3", supporting 30 psf Snow Load (115%) and 15 psf Dead Load, spaced 24" oc, with a slope of 4:12. Select a joist that satisfies an L/240 live load deflection limit.

- Sloped Span = $(32 + 3/12) * 1.054 = 33.99'$
Select the row corresponding to a 34' span.
- Design Total Load = $(30 + 15) * (24 / 12) = 90$ plf
Design Live Load = $30 * (24 / 12) = 60$ plf
- Select the first I-Joist to exceed both Total Load for Snow (115%) and L/240.

The 16" LPI 56 supports 90 plf Total Load (Snow 115%) and 67 plf Live Load at L/240

NOTE: Web stiffeners required at both end supports.

Span (ft)	11-7/8" LPI 56				14" LPI 56				16" LPI 56				Span (ft)
	Live Load		Total Load		Live Load		Total Load		Live Load		Total Load		
	L/360	L/240	Snow 115%	Non-Snow 125%	L/360	L/240	Snow 115%	Non-Snow 125%	L/360	L/240	Snow 115%	Non-Snow 125%	
12'			221 / 318	240 / 345			221 / 339	240 / 368			221 / 359	241 / 390	12'
13'			204 / 294	222 / 319			204 / 313	222 / 341			205 / 332	223 / 360	13'
14'	275		190 / 273	206 / 297			190 / 291	207 / 317			190 / 308	207 / 335	14'
15'	230		177 / 255	193 / 277			178 / 272	193 / 296			178 / 288	193 / 313	15'
16'	194		166 / 240	181 / 265	270		167 / 255	181 / 278			167 / 270	181 / 294	16'
17'	165		157 / 226	170 / 245	231		157 / 241	171 / 262			157 / 255	171 / 277	17'
18'	142	213	148 / 213	161 / 232	199		148 / 227	161 / 247	259		149 / 241	162 / 262	18'
19'	122	184	140 / 202	153 / 220	172		141 / 216	153 / 234	225		141 / 228	153 / 248	19'
20'	106	160	133 / 192	145 / 209	150		134 / 205	145 / 223	197		134 / 217	146 / 236	20'
21'	93	140	127 / 183	138 / 186	131	197	127 / 195	139 / 212	173		128 / 207	139 / 225	21'
22'	82	123	121 / 164	132 / 164	116	174	122 / 187	132 / 203	152		122 / 197	133 / 215	22'
23'	72	108	116 / 144	126 / 144	102	154	116 / 179	127 / 194	135	203	117 / 189	127 / 205	23'
24'	64	96	111 / 128	121 / 128	91	137	112 / 171	121 / 182	120	180	112 / 181	122 / 197	24'
25'	57	86	107 / 114	114	81	122	107 / 163	117 / 163	107	161	107 / 174	117 / 189	25'
26'	51	76	102	102	73	109	103 / 146	112 / 146	96	144	103 / 167	112 / 182	26'
27'	46	69	92	92	65	98	99 / 131	108 / 131	86	130	99 / 161	108 / 173	27'
28'	41	62	83	83	59	88	96 / 118	104 / 118	78	117	96 / 156	104 / 157	28'
29'	37	56	75	75	53	80	92 / 107	101 / 107	71	106	93 / 142	101 / 142	29'
30'	34	51	68	68	48	73	89 / 97	97	64	97	90 / 129	97 / 129	30'
31'	31	46	62	62	44	66	87	88	58	88	87 / 117	94 / 117	31'
32'	28	42	56	56	40	60	81	81	53	80	84 / 107	91 / 107	32'
33'	25	38	51	51	37	55	74	74	49	74	81 / 98	89 / 98	33'
34'	23	35	47	47	34	51	68	68	45	67	79 / 90	86 / 90	34'
35'	21	32	43	43	31	46	62	62	41	62	77 / 83	83	35'
36'	20	30	40	40	28	43	57	57	38	57	75 / 76	76	36'
37'	18	27	37	37	26	40	53	53	35	53	71	71	37'
38'	17	25	34	34	24	37	49	49	32	49	65	65	38'

Span (ft)	18" LPI 56				24" LPI 56				Span (ft)
	Live Load		Total Load		Live Load		Total Load		
	L/360	L/240	Snow 115%	Non-Snow 125%	L/360	L/240	Snow 115%	Non-Snow 125%	
12'			243 / 426	264 / 463			248 / 513	269 / 557	12'
13'			225 / 394	245 / 428			229 / 474	249 / 516	13'
14'			209 / 366	228 / 398			213 / 441	232 / 480	14'
15'			196 / 343	213 / 372			199 / 413	217 / 449	15'
16'			184 / 322	200 / 350			187 / 388	204 / 421	16'
17'			173 / 303	188 / 330			176 / 365	192 / 397	17'
18'			164 / 287	178 / 312			167 / 345	181 / 376	18'
19'	282		155 / 272	169 / 296			158 / 328	172 / 356	19'
20'	246		148 / 259	161 / 281			150 / 312	164 / 339	20'
21'	217		141 / 247	153 / 268			143 / 297	156 / 323	21'
22'	192		134 / 235	146 / 256			137 / 284	149 / 308	22'
23'	170		129 / 225	140 / 245			131 / 272	143 / 295	23'
24'	152	228	123 / 216	134 / 235	267		126 / 260	137 / 283	24'
25'	136	204	118 / 208	129 / 226	240		121 / 250	131 / 272	25'
26'	122	183	114 / 200	124 / 217	216		116 / 241	126 / 262	26'
27'	110	165	110 / 192	119 / 209	195		112 / 232	122 / 252	27'
28'	99	149	106 / 185	115 / 199	177		108 / 224	117 / 243	28'
29'	90	135	102 / 172	111 / 180	161		104 / 216	113 / 235	29'
30'	82	123	99 / 161	108 / 164	147	220	101 / 209	110 / 227	30'
31'	75	112	96 / 150	104 / 150	134	201	98 / 201	106 / 219	31'
32'	68	102	93 / 137	101 / 137	123	185	95 / 189	103 / 205	32'
33'	62	94	90 / 125	98 / 125	113	169	92 / 178	100 / 193	33'
34'	57	86	87 / 115	95 / 115	104	156	89 / 167	97 / 182	34'
35'	53	79	85 / 106	92 / 106	96	144	87 / 158	94 / 172	35'
36'	49	73	83 / 98	90 / 98	88	133	84 / 149	91 / 162	36'
37'	45	68	80 / 90	87 / 90	82	123	82 / 141	89 / 154	37'
38'	42	63	78 / 84	84	76	114	80 / 134	87 / 146	38'

DESIGN ASSUMPTIONS:

- Span is the clear distance between supports, along the sloped length of the joist, for simple span applications only.
- The values in the tables are for uniform loads only and represent the design gravity loads, unadjusted for roof pitch. Wind uplift has not been considered.
- Total Load is for Snow (115%) or Non-Snow (125%) duration as noted.
- These tables do not reflect any additional stiffness provided by the roof sheathing.
- Total deflection is limited to L/180. Long term deflection (creep) has not been considered.
- Live Load deflection is limited to L/360 or L/240 as noted in the table.
- These tables assume full lateral support of the compression flange (maximum unbraced length of 24"). Design for wind may require bracing of the bottom flange and special connectors to resist uplift.
- The spans are based on an end bearing length of at least 1-3/4" for depths up to 16" and at least 2-1/2" for depths greater than 16", and are limited to the bearing capacity for an SPF wall plate ($F_{CL} = 425$ psi).

ADDITIONAL NOTES:

- The allowable loads represent the capacity of the joist in pounds per lineal foot (plf) of length.
- The designer shall check the appropriate Total Load and the Live Load column.
- For roofs with a pitch of 2:12 or greater, the horizontal span shall be multiplied by the appropriate adjustment factor from the table at the bottom of this page.
- To design a double I-Joist, the values in these tables can be doubled, or the design loads on the I-Joist may be halved to verify the capacity of each ply. The capacity is additive.
- Web stiffeners are not required where only one value is shown for Total Load or when the design total load does not exceed the first value (capacity without stiffeners) in the Total Load column where two values are given. Web stiffeners are required at both end supports if the design total load exceeds the first value. Do not exceed the second value (capacity with stiffeners).
- Web fillers are required for I-Joists seated in hangers that do not laterally support the top flange or for hangers that require nailing into the web.
- Where the Live Load is blank, the Total Load governs the design.
- To design for a live load deflection limit of L/600 or L/480, use the Uniform Floor Load tables.
- Do not use a product where designated "-" without further analysis by a design professional.

ROOF PITCH ADJUSTMENT FACTORS											
Roof Pitch	2:12	3:12	4:12	5:12	6:12	7:12	8:12	9:12	10:12	11:12	12:12
Factor	1.014	1.031	1.054	1.083	1.118	1.158	1.202	1.250	1.302	1.357	1.414

Uniform Roof Load (PLF) Tables: LPI 56 Continuous Spans

TO USE:

- Select the span required. For roofs with a pitch of 2:12 or greater, the horizontal span shall be multiplied by the appropriate roof pitch adjustment factor from the table at the bottom of this page.
- Compare the design total load to the appropriate Total Load column for Snow (115%) or Non-Snow (125%). Where two numbers are shown, the first number represents the Total Load capacity without web stiffeners. The second number represents the Total Load capacity with stiffeners. (See Additional Notes below.)
- Compare the design live load to the appropriate Live Load column (L/360 or L/240). For live load deflection limits of L/600 or L/480, compare the design live load to the appropriate Live Load column from the Uniform Floor Load Tables on pages 6-13.
- Select a product that exceeds both the design total and live loads.
- Specify web stiffeners as dictated by the Total Load column.

EXAMPLE:

An I-Joist has the horizontal clear span of 20'-8" and 32'-3", supporting 30 psf Snow Load (115%) and 15 psf Dead Load, spaced 24" oc, with a slope of 4:12. Select a joist that satisfies an L/240 live load deflection limit.

- Sloped Span = $(32 + 3/12) * 1.054 = 33.99'$ (use the longest span)
Select the row corresponding to a 34' span.
- Design Total Load = $(30 + 15) * (24 / 12) = 90$ plf
Design Live Load = $30 * (24 / 12) = 60$ plf
- Select the first I-Joist to exceed both Total Load for Snow (115%) and L/240:

The 16" LPI 56 supports 111 plf Total Load (Snow 115%) and 88 plf Live Load at L/240

NOTE: Web stiffeners required at the intermediate support and at both end supports.

Span (ft)	11-7/8" LPI 56				14" LPI 56				16" LPI 56				Span (ft)
	Live Load		Total Load		Live Load		Total Load		Live Load		Total Load		
	L/360	L/240	Snow 115%	Non-Snow 125%	L/360	L/240	Snow 115%	Non-Snow 125%	L/360	L/240	Snow 115%	Non-Snow 125%	
12'			234 / 288*	254 / 314*			234 / 303*	254 / 329*			234 / 317*	254 / 329*	12'
13'			216 / 267*	235 / 290*			216 / 280*	235 / 304*			216 / 293*	235 / 304*	13'
14'			201 / 248*	219 / 270*			201 / 261*	219 / 283*			201 / 273*	219 / 283*	14'
15'			188 / 232*	204 / 252*			188 / 243*	204 / 264*			188 / 255*	204 / 264*	15'
16'			176 / 217*	192 / 236*			176 / 228*	192 / 248*			176 / 238*	192 / 248*	16'
17'	213		166 / 205*	181 / 223*			166 / 215*	181 / 233*			166 / 225*	181 / 233*	17'
18'	183		157 / 194*	171 / 211*			157 / 203*	171 / 221*			157 / 213*	171 / 221*	18'
19'	158		149 / 184*	162 / 200*			149 / 193*	162 / 209*			149 / 202*	162 / 209*	19'
20'	138		141 / 175*	154 / 190*	194		141 / 183*	154 / 199*			141 / 192*	154 / 199*	20'
21'	120	181	135 / 166*	147 / 181*	170		135 / 175*	147 / 190*			135 / 183*	147 / 190*	21'
22'	106	159	129 / 159*	140 / 173*	150		129 / 167*	140 / 181*			129 / 175*	140 / 181*	22'
23'	93	140	123 / 152*	134 / 165*	133		123 / 160*	134 / 173*			123 / 167*	134 / 173*	23'
24'	83	125	118 / 146*	128	118		118 / 153*	128 / 166*	155		118 / 160*	128 / 166*	24'
25'	74	111	113	123	105	158	113 / 147*	123 / 159*	139		113 / 154*	123 / 159*	25'
26'	66	99	109	119	94	142	109 / 141*	119 / 153*	125		109 / 148*	119 / 153*	26'
27'	59	89	105	114	85	127	105 / 136*	114 / 148*	112		105 / 143*	114 / 148*	27'
28'	54	81	101	108	77	115	101 / 131*	110 / 143*	101		101 / 138*	110 / 143*	28'
29'	48	73	97	97	69	104	98 / 127*	106	92		98 / 133*	106 / 138*	29'
30'	44	66	88	88	63	95	95	103	84	126	95 / 128*	103 / 133*	30'
31'	40	60	80	80	57	86	92	100	76	114	92 / 124*	100 / 129*	31'
32'	36	55	73	73	52	79	89	96	70	105	89 / 120*	96 / 125*	32'
33'	33	50	67	67	48	72	86	94	64	96	86 / 117*	94 / 121*	33'
34'	30	46	61	61	44	66	83	88	59	88	83 / 111*	91	34'
35'	28	42	56	56	40	61	81	81	54	81	81	88	35'
36'	26	39	52	52	37	56	75	75	50	75	79	86	36'
37'	24	36	48	48	34	52	69	69	46	69	77	83	37'
38'	22	33	44	44	32	48	64	64	42	64	75	81	38'

Span (ft)	18" LPI 56				24" LPI 56				Span (ft)
	Live Load		Total Load		Live Load		Total Load		
	L/360	L/240	Snow 115%	Non-Snow 125%	L/360	L/240	Snow 115%	Non-Snow 125%	
12'			233 / 327*	253 / 327*			233 / 327*	253 / 327*	12'
13'			215 / 302*	234 / 302*			215 / 302*	234 / 302*	13'
14'			200 / 281*	218 / 281*			200 / 281*	218 / 281*	14'
15'			187 / 263*	203 / 263*			187 / 263*	203 / 263*	15'
16'			176 / 247*	191 / 247*			176 / 247*	191 / 247*	16'
17'			165 / 233*	180 / 233*			165 / 233*	180 / 233*	17'
18'			156 / 220*	170 / 220*			156 / 220*	170 / 220*	18'
19'			148 / 209*	161 / 209*			148 / 209*	161 / 209*	19'
20'			141 / 198*	153 / 198*			141 / 198*	153 / 198*	20'
21'			134 / 189*	146 / 189*			134 / 189*	146 / 189*	21'
22'			128 / 180*	140 / 180*			128 / 180*	140 / 180*	22'
23'			123 / 173*	134 / 173*			123 / 173*	134 / 173*	23'
24'			118 / 166*	128 / 166*			118 / 166*	128 / 166*	24'
25'			113 / 159*	123 / 159*			113 / 159*	123 / 159*	25'
26'			109 / 153*	118 / 153*			109 / 153*	118 / 153*	26'
27'	143		105 / 147*	114 / 147*			105 / 147*	114 / 147*	27'
28'	129		101 / 142*	110 / 142*			101 / 142*	110 / 142*	28'
29'	117		98 / 137*	106 / 137*			98 / 137*	106 / 137*	29'
30'	107		94 / 133*	103 / 133*			94 / 133*	103 / 133*	30'
31'	97		91 / 129*	99 / 129*			91 / 129*	99 / 129*	31'
32'	89		89 / 125*	96 / 125*			89 / 125*	96 / 125*	32'
33'	82		86 / 121*	93 / 121*			86 / 121*	93 / 121*	33'
34'	75	113	83 / 117*	91 / 117*			83 / 117*	91 / 117*	34'
35'	69	104	81 / 114*	88 / 114*			81 / 114*	88 / 114*	35'
36'	64	96	79 / 111*	86 / 111*			79 / 111*	86 / 111*	36'
37'	59	88	77 / 106*	83 / 108*	107		77 / 108*	83 / 108*	37'
38'	54	82	75 / 100*	81 / 105*	99		75 / 105*	81 / 105*	38'

DESIGN ASSUMPTIONS:

- Span is the clear distance between supports, along the sloped length of the joist, for continuous span applications only. Continuous spans are based on the longest span. The shortest span shall not be less than 50% of the longest span.
- The values in the tables are for uniform loads only and represent the design gravity loads, unadjusted for roof pitch. Wind uplift has not been considered.
- Total Load is for Snow (115%) or Non-Snow (125%) duration as noted.
- These tables do not reflect any additional stiffness provided by the roof sheathing.
- Total deflection is limited to L/180. Long term deflection (creep) has not been considered.
- Live Load deflection is limited to L/360 or L/240 as noted in the table.
- These tables assume full lateral support of the compression flange (maximum unbraced length of 24'). Design for wind may require bracing of the bottom flange and special connectors to resist uplift.
- The spans are based on an end bearing length of at least 1-3/4" for depths up to 16" and at least 2-1/2" for depths greater than 16"; an intermediate bearing length of at least 3-1/2" and are limited to the bearing capacity for an SPF wall plate ($F_{c\perp} = 425$ psi).

ADDITIONAL NOTES:

- The allowable loads represent the capacity of the joist in pounds per lineal foot (plf) of length.
- The designer shall check the appropriate Total Load and the Live Load column.
- For roofs with a pitch of 2:12 or greater, the horizontal span shall be multiplied by the appropriate adjustment factor from the table at the bottom of this page.
- To design a double I-Joist, the values in these tables can be doubled, or the design loads on the I-Joist may be halved to verify the capacity of each ply. The capacity is additive.
- Web stiffeners are not required where only one value is shown for Total Load or when the design total load does not exceed the first value (capacity without stiffeners) in the Total Load column where two values are given. Web stiffeners are required at interior supports if the design total load exceeds the first value. Do not exceed the second value (capacity with stiffeners). If the capacity with stiffeners is marked "*", then web stiffeners are also required at both end supports.
- Web fillers are required for I-Joists seated in hangers that do not laterally support the top flange or for hangers that require nailing into the web.
- Where the Live Load is blank, the Total Load governs the design.
- To design for a live load deflection limit of L/600 or L/480, use the Uniform Floor Load tables.
- Do not use a product where designated "-" without further analysis by a design professional.

ROOF PITCH ADJUSTMENT FACTORS											
Roof Pitch	2:12	3:12	4:12	5:12	6:12	7:12	8:12	9:12	10:12	11:12	12:12
Factor	1.014	1.031	1.054	1.083	1.118	1.158	1.202	1.250	1.302	1.357	1.414

Roof Details

<p>J1 RAFTER CONNECTION</p> <p>Simpson® LSTA24, MiTek® LSTI-22 strap or equal</p> <p>LPI blocking⁵</p> <p>Support beam or wall</p> <p>Beveled plate</p>	<p>J2 RAFTER CONNECTION WITH FITTED OSB GUSSET</p> <p>Simpson® LSTA24, MiTek® LSTI-22 strap (or equal) for pitch over 7:12</p> <p>23/32" x 2'-0" OSB with 8-16d nails each side min. 1/8" gap at top</p> <p>LPI blocking⁵</p> <p>Support beam or wall</p> <p>Beveled plate</p>	<p>J3 RIDGE RAFTER CONNECTION</p> <p>Web filler required each side</p> <p>Simpson LSTA24, MiTek LSTI-22 strap (or equal) for pitch over 7:12</p> <p>Structural beam</p> <p>Simpson LSSU, USP TMU (or equal) hanger</p>
---	--	---

<p>J4 HEADER CONNECTION</p> <p>Simpson LSTA24, USP LSTI-22 strap (or equal) for pitch over 7:12</p> <p>Simpson LSSR, MiTek TMU (or equal) hanger</p> <p>Header</p> <p>Web filler required each side</p>	<p>H1 BIRD'S MOUTH (Lower bearing only)</p> <p>Don't cut beyond inside face of bearing</p> <p>Cut to fit tight to wall plate</p> <p>LPI blocking⁵</p> <p>Beveled web stiffeners required both sides</p> <p>2'-0" max.</p>	<p>H2 BEVELED PLATE</p> <p>LPI blocking⁵</p> <p>2x beveled plate</p> <p>Simpson VPA, USP TMP (or equal) connector may be substituted for beveled plate</p>
--	---	--

<p>H3 FLAT SOFFIT (Fascia Support)</p> <p>LPI blocking⁵</p> <p>8d nails at 6" oc clinched</p> <p>Beveled plate</p> <p>2 x 4 cut to fit</p> <p>2'-0" max.</p>	<p>H4 OVERHANG</p> <p>8d nails at 6" oc staggered and clinched</p> <p>LPI blocking⁵</p> <p>4'-0" min.</p> <p>2 x 4 cut to fit both sides</p> <p>2 x 4 filler</p> <p>2'-0" max.</p>	<p>H5 OVERHANG</p> <p>8d nails at 6" oc 1" from edge</p> <p>LPI blocking⁵</p> <p>4'-0" min.</p> <p>2 x 4 cut to fit</p> <p>Beveled plate</p> <p>8d or 10d box toe-nail to plate</p> <p>Web fillers required both sides of I-Joist</p> <p>2'-0" max.</p>
--	--	---

<p>K1 ROOF OPENING Hanger Connections</p> <p>Simpson LSTA24, MiTek LSTI-22 strap (or equal) for pitch over 7:12</p> <p>Simpson LSSU, USP TMU (or equal) hanger</p> <p>Web filler</p> <p>Filler on back side</p> <p>Install header plumb</p> <p>Filler block</p> <p>Web filler</p>	<p>K2 OUTRIGGER</p> <p>8d nails staggered at 6" oc</p> <p>Maximum overhang same as rafter spacing (2'-0" max.)</p> <p>2 x 4 filler</p> <p>Ladder</p> <p>Gable end</p>
--	--

NOTES:

1. Minimum pitch: 1/4" per foot (1/4:12). Maximum pitch: 12" per foot (12:12).
2. Verify capacity and fastening requirements of hangers and connectors.
3. Some wind or seismic loads may require different or additional details and connections. Uplift anchors may be required.
4. 4" diameter hole(s) may be cut in blocking for ventilation.
5. Lateral resistance shall be provided. Other methods of restraint, such as full depth LP SolidStart OSB Rim Board, LP® SolidStart® LVL, or metal X-bracing may be substituted for the LP blocking shown.

Sprinkler Details

S2

SPRINKLER SUPPORT
Assembly Capacity 475 lbs.

Fastener

4x6 cross member requires two 16d (3-1/2") nails per end

2x6 block requires two 1/2" A307 bolts bolted through web

U-type hanger per NFPA 13

Verify hanger capacity with manufacturer.

NOTES:

- Holes for bolts shall be between 1/32" and 1/16" greater than the diameter of the bolt.
- Provide a flat washer and nut for bolts.
- Use three 16d (3-1/2") common nails to attach cross member to web.
- Lag screw fastener for rod should be located 1" from top of cross member.
- Consult NFPA 13 for lag screw dimensions and maximum supported pipe diameter.
- Sprinkler support should be centered between the joists.
- Spacing between joists is limited to 48" oc.
- Framing members to be SPF or better.

S3

SPRINKLER SUPPORT
Assembly Capacity 270 lbs.

Fastener

4x6 cross member requires three 16d (3-1/2") nails per end

U-type hanger per NFPA 13

Verify hanger capacity with manufacturer.

NOTES:

- Use three 16d (3-1/2") common nails to attach cross member to web.
- Lag screw fastener for hanger should be located 2-1/2" from bottom of cross member for branch lines and 3" for mains.
- Consult NFPA 13 for lag screw dimensions and maximum supported pipe diameter.
- Sprinkler support should be centered between the joists.
- Spacing between joists is limited to 48" oc.
- Framing members to be SPF or better.

S4

SPRINKLER SUPPORT
Assembly Capacity 240 lbs.

2x6 block requires two 1/2" A307 bolts bolted through web

U-type hanger per NFPA 13

Verify hanger capacity with manufacturer.

NOTES:

- Holes for bolts shall be between 1/32" and 1/16" greater than the diameter of the bolt.
- Provide flat washer and nut for bolts.
- Bolts should be located 2-1/2" from bottom of block.
- Consult NFPA 13 for maximum supported pipe diameter.
- Framing members to be SPF or better.

S7

SPRINKLER SUPPORT
Assembly Capacity 270 lbs.

Fastener

4x6 cross member requires three 16d (3-1/2") nails per end

U-type hanger per NFPA 13

Verify hanger capacity with manufacturer.

NOTES:

- Use three 16d (3-1/2") common nails to attach cross member to web.
- Lag screw fastener for rod should be located 2-1/2" from bottom of cross member for branch lines and 3" for mains.
- Consult NFPA 13 for lag screw dimensions and maximum supported pipe diameter.
- Sprinkler support should be centered between joists.
- Joist spacing is limited to 48" oc.
- Framing members to be SPF or better.

S8

SPRINKLER SUPPORT
Assembly Capacity 240 lbs.

Hole through web

2x6 block requires two 1/2" A307 bolts bolted through web

Inverted U-type hanger per NFPA 13

Hanger per NFPA 13.
Verify hanger capacity with manufacturer.

NOTES:

- Holes for bolts shall be between 1/32" and 1/16" greater than the diameter of the bolt.
- Provide a flat washer and nut for bolts.
- Bolts should be located 2-1/2" from bottom of block.
- Consult NFPA 13 for maximum supported pipe diameter.
- See product specific technical guide for hole sizes and location.
- Framing members to be SPF or better.

S9

SPRINKLER SUPPORT
Assembly Capacity 90 lbs.

3/8" minimum machine bolt through web

Side beam bracket

2x6 Block

Verify hanger capacity with manufacturer.

NOTES:

- Holes for bolts shall be between 1/32" and 1/16" greater than the diameter of the bolt.
- Provide a flat washer and nut for bolts.
- Bolts should be located 2-1/2" from bottom of block.
- Consult NFPA 13 for maximum supported pipe diameter.
- Side beam bracket per NFPA 13.
- Framing members to be SPF or better.

LP® SolidStart® Rim Board

RIM BOARD CAPACITIES						
Material	Grade	Thickness	Vertical Load Capacity ¹			Lateral ^{4,5,6} Load Capacity (plf)
			Uniform ² (plf)		Concentrated ³ (lbs)	
			d ≤ 16"	16" < d ≤ 24"	d ≤ 24"	
LP OSB	APA C2/Rim Board ⁷	1"	3300	1650	3500	180
	APA C1/Rim Board ⁷	1-1/8"	4400	3000	3500	180

NOTES:

- The Vertical Load Capacity shall not be increased for short-term load duration.
- Uniform Vertical Load Capacity is based on the capacity of the rim board and may need to be reduced based on the bearing capacity of the supporting wall plate or the attached floor sheathing. Example: The allowable bearing stress for commodity floor sheathing is 360 psi so the bearing capacity of a 1-1/4" x 16" deep rim board would be limited to 5400 plf (360 psi x 1-1/4" x 12).
- The Concentrated Vertical Load capacity is assumed to be applied through a minimum 4-1/2" bearing length (3-stud post).
- The Lateral Load Capacity is based on a short-term load duration and shall not be increased.
- The Lateral Load Capacity is based on the connections specified in the Installation details below.
- Additional framing connectors fastened to the face of the rim board may be used to increase lateral capacity for wind and seismic design.
- The APA C1 and C2 grades in product standard ANSI/APA PRR 410-2011 are equivalent to the rim board grade in product standard APA PRR-401.

ALLOWABLE UNIFORM LOADS (PLF) FOR RIM BOARD HEADERS: MAXIMUM 4' CLEAR SPAN					
Material	Thickness	Rim Board Depth			
		9-1/2"	11-7/8"	2-Ply 14"	2-Ply 16"
LP OSB	1"	330 (1-1/2")	480 (3")	1280 (3")	1670 (4-1/2")
	1-1/8"	370 (1-1/2")	540 (3")	1440 (3")	1880 (4-1/2")

NOTES:

- This table is for preliminary design for uniform gravity loads only. Final design should include a complete analysis of all loads and connections.
- The allowable loads are for a maximum 4' clear span with minimum bearings for each end (listed in parentheses) based on the bearing capacity of the rim board. For headers bearing on wood plates, the bearing length may need to be increased based on the ratio of the bearing capacity of the rim board divided by the bearing capacity of the plate species.
- Normal load duration is assumed and shall be adjusted according to code.
- Depths greater than 11-7/8" shall be used with a minimum of two plies, as shown. Depths of 11-7/8" and less may be used as a two-ply header by multiplying the allowable loads by two.
- Multiple-ply headers shall be toe-nailed to the plate from both faces. Fasten the floor sheathing to the top of each ply to provide proper lateral support for each ply.
- For multiple-ply headers supporting top-loads only, fasten plies together with minimum 8d box nails (2-1/2" x 0.113") at a maximum spacing of 12" oc. Use 2 rows of nails for 9-1/2" and 11-7/8". Use 3 rows for depths 14" and greater. Clinch the nails where possible. For side-loaded multiple-ply headers, refer to the Connection Capacity For Side-Loaded 2-Ply Rim Board Headers table below for the required nailing and the allowable side load that can be applied.
- The designer shall verify proper bearing for the header.
- Joints in the rim are not allowed over openings and must be located at least 12" from any opening.
- Refer to the "APA Performance Rated Rim Boards" (Form No. W345) for additional information including allowable loads for smaller openings.

CONNECTION CAPACITY FOR SIDE-LOADED 2-PLY RIM BOARD HEADERS (PLF)						
Material	Thickness	Minimum Nail Size	3 Rows of Nails at 6" oc	4 Rows of Nails at 6" oc	5 Rows of Nails at 6" oc	6 Rows of Nails at 6" oc
LP OSB	1" & 1-1/8"	8d (2-1/2" x 0.113")	768	1024	1280	1536

NOTES:

- This table represents the uniform side-load capacity of the connection for a 2-ply header. The total applied uniform load, including top-load and side-load, shall not exceed the allowable uniform load capacity of the header as tabulated above.
- The tabulated side-load capacity is for normal load duration and shall be adjusted according to code.
- Use 3 rows of nails for 9-1/2" and 11-7/8"; 4 rows for 14" and 16"; 5 rows for 18" and 20"; 6 rows for 22" and 24" deep rim board. Clinch the nails where possible.
- Headers consisting of more than 2 plies, alternate fastening or higher side loads are possible but require proper design of the connection.

INSTALLATION

RIM TO JOIST CONNECTION

Nail rim to I-joist with one 8d (box or common) or 10d box nail into each flange.

DECK TO RIM AND RIM TO PLATE CONNECTIONS¹

- Nail floor sheathing to rim board with 8d nails at 6" oc.
- Nail wall plate through floor sheathing into rim per code.
- Toe-nail rim board to wall plate with 8d nails at 6" oc.

See T&G Trim Requirements detail and table.

T&G TRIM REQUIREMENTS²

See T&G Trim Requirements table below for when to trim tongue or groove.

Trim tongue (or groove) Trim not required

NOTE:

- Additional framing connectors to the face of the rim board may be used to increase lateral capacity for wind and seismic design.
- Trim the tongue or groove of the floor sheathing in accordance with the T&G Trim Requirements table.

T&G TRIM REQUIREMENTS				
Floor Sheathing Thickness	Rim Board Thickness			
	1"	1-1/8"	1-1/4"	> 1-1/4"
≤ 7/8"	Trim	Not Required	Not Required	Not Required
> 7/8"	Trim	Trim	Trim	Not Required

Warnings

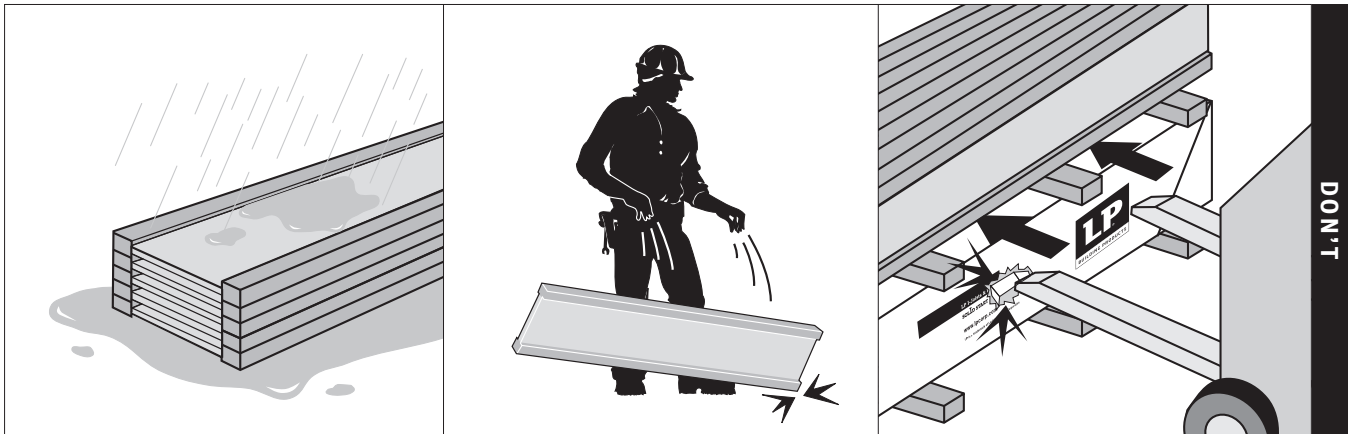

WARNINGS

The following conditions are **NOT** permitted!

Do not use visually damaged products without first checking with your local LP SolidStart Engineered Wood Products distributor or sales office.

<p>DON'T put holes too close to supports.</p> <p>Refer to hole chart for correct location.</p>	<p>DON'T overcut hole and damage flange.</p>	<p>DON'T make hole with hammer unless knock-out is provided.</p> <p>DON'T hammer on flange and damage joist.</p>	<p>DON'T cut or notch flange.</p> <p>DON'T drill flange.</p>
<p>DON'T cut flange for pipes.</p>	<p>DON'T use 16d nails.</p> <p>Refer to Joist End Nailing detail for correct sizes and locations.</p>	<p>DON'T cut beyond inside edge of bearing.</p>	<p>DON'T support I-Joist on web.</p>

HANDLING & STORAGE GUIDELINES

- **WARNING:** Failure to follow proper procedures for handling, storage and installation could result in unsatisfactory performance, unsafe structures and possible collapse.
- Keep LP® SolidStart® Engineered Wood Products dry. These products are intended to resist the effects of moisture on structural performance from normal construction delays but are not intended for permanent exposure to the weather.
- Unload products carefully, by lifting. Support the bundles to reduce excessive bowing. Individual products should be handled in a manner which prevents physical damage during measuring, cutting, erection, etc. I-Joists shall be handled vertically and not flatwise.
- Keep products stored in wrapped and strapped bundles, stacked no more than 10' high. Support and separate bundles with 2 x 4 (or larger) stickers spaced no more than 10' apart. Keep stickers in line vertically.
- Product must not be stored in contact with the ground, or have prolonged exposure to the weather.
- Use forklifts and cranes carefully to avoid damaging product.
- Do not use a visually damaged product. Call your local LP SolidStart Engineered Wood Products distributor for assistance when damaged products are encountered.
- For satisfactory performance, LP SolidStart Engineered Wood Products must be used under dry, covered and well-ventilated interior conditions in which the equivalent moisture content in lumber is less than 16%.
- For built-up members, LP SolidStart I-Joists and LVL shall be dry before nailing or bolting to avoid trapping moisture.
- LP SolidStart I-Joists and LVL shall not be used for unintended purposes such as ramps and planks.

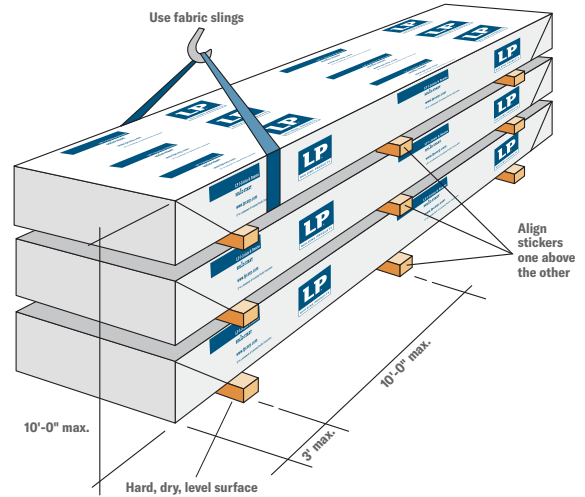

LP SolidStart I-JOISTS

LPI 36

Width: 2-1/4"
Depths: 11-7/8", 14", 16", 18"
Web Thickness: 3/8"
Flange Material: LVL
Flange Depth: 1-1/2"

LPI 42Plus

Width: 3-1/2"
Depths: 11-7/8", 14", 16", 18", 20", 24"
Web Thickness: 3/8" or 7/16"
Flange Material: Solid Sawn
Flange Depth: 1-1/2"

LPI 52Plus

Width: 3-1/2"
Depths: 11-7/8", 14", 16"
Web Thickness: 7/16"
Flange Material: Solid Sawn
Flange Depth: 1-1/2"

LPI 56

Width: 3-1/2"
Depths: 11-7/8", 14", 16", 18", 24"
Web Thickness: 7/16"
Flange Material: LVL
Flange Depth: 1-1/2"

CODE EVALUATION

Code evaluation reports can be obtained at www.lpcorp.com

ICC ESR 1305

APA PR-L238

For more information on the full line of LP SolidStart Engineered Wood Products or the nearest distributor, visit our web site at LPCorp.com.

Phone: 1-888-820-0325

E-mail: customer.support@LPCorp.com.

LP SolidStart Engineered Wood Products are manufactured at different locations in the United States and Canada.

Please verify availability with the LP SolidStart Engineered Wood Products distributor in your area before specifying these products.



For product catalog & complete warranty details, visit LPCorp.com

⚠ CAL. PROP 65 WARNING: Drilling, sawing, sanding or machining wood products can expose you to wood dust, a substance known to the State of California to cause cancer. Avoid inhaling wood dust or use a dust mask or other safeguards for personal protection. For more information go to www.P65Warnings.ca.gov/wood.

© 2021 Louisiana-Pacific Corporation. All rights reserved. APA and APA Rated are registered trademarks of APA - The Engineered Wood Association. SIMPSON Strong-Tie® is a registered trademark of Simpson Strong-Tie Company, Inc. MiTek® is a registered trademark of MiTek Holdings, Inc. LP® and SolidStart® are registered trademarks of Louisiana-Pacific Corporation. Printed in USA. Specifications (details) subject to change without notice. NOTE: Louisiana-Pacific Corporation periodically updates and revises its product information. To verify that this version is current, contact the nearest sales office, visit LPCorp.com, or call 1-888-820-0325.

LPEW0325 6/21 OS/ARGENT