



# TECH GUIDE

## PWT TREATED LVL

---

STAIR STRINGERS

---

**PWT** FOCUSED ON EWP



# No-Cut Stringer

Why spend lots of time and money removing the stiffness (increasing bounce) of a PWT Treated™ LVL stair stringer?

Cutting the stringer for the treads removes 50% of wood but reduces the stiffness by 80%.

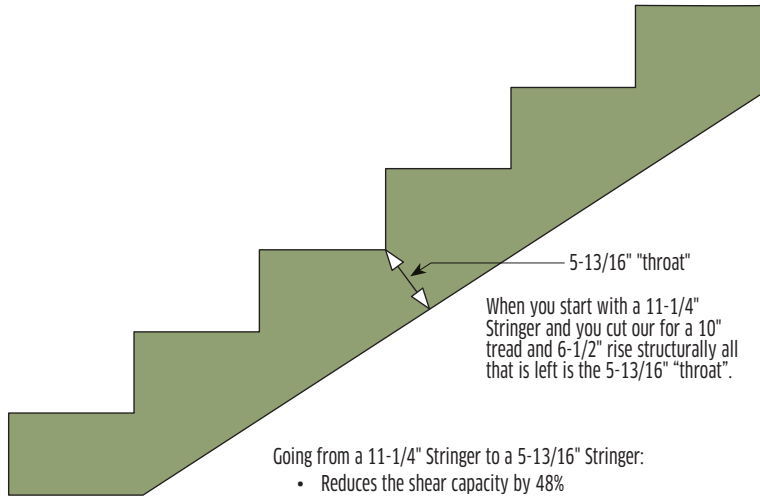

Going from a 11-1/4" Stringer to a 5-13/16" Stringer:

- Reduces the shear capacity by 48%
- Reduces the moment (bending) capacity by 73%
- Reduces the stiffness by approximately 80%



## PWT TREATED LVL BOX - WITH COMPOSITE TREAD

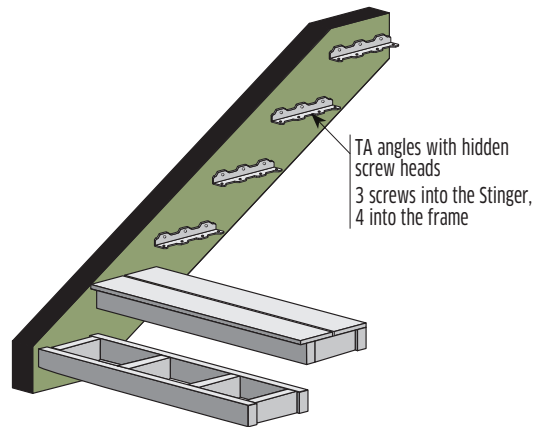

Leave 3/8" for the heads of the SDS screws

7-1/4" min.



(2) 3" galvanized nails each end

## PRECAST CONCRETE TREAD

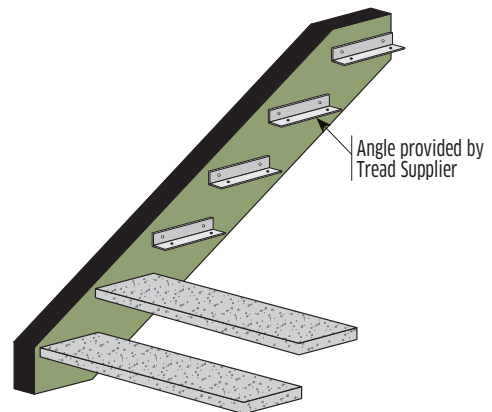

# No-Cut Stringer

## Maximum Horizontal Stringer Run

### DRY USE

	Tread Length	40 psf Live, 12 psf Tread Dead Load				60 psf Live, 12 psf Tread Dead Load				100 psf Live, 12 psf Tread Dead Load				
		36	42	44	48	36	42	44	48	36	42	44	48	
Lightweight Tread	1-1/2" x 9-1/4"	15'-10"	15'-0"	14'-10"	14'-5"	13'-10"	13'-2"	12'-11"	12'-7"	11'-8"	11'-1"	10'-11"	10'-7"	
	1-1/2" x 11-1/4"	19'-6"	18'-6"	18'-3"	17'-8"	17'-0"	16'-2"	15'-11"	15'-6"	14'-5"	13'-8"	13'-6"	13'-1"	
	1-3/4" x 11-7/8"	21'-8"	20'-7"	20'-3"	19'-9"	19'-0"	18'-0"	17'-9"	17'-3"	16'-0"	15'-3"	15'-0"	14'-7"	
	1-3/4" x 14"	25'-9"	24'-6"	24'-1"	23'-5"	22'-7"	21'-5"	21'-1"	20'-6"	19'-1"	18'-2"	17'-11"	17'-5"	
	2-ply 1-1/2" x 9-1/4"	19'-11"	18'-11"	18'-8"	18'-1"	17'-5"	16'-7"	16'-4"	15'-10"	14'-8"	13'-11"	13'-9"	13'-4"	
	2-ply 1-1/2" x 11-1/4"	24'-5"	23'-3"	22'-11"	22'-3"	21'-5"	20'-4"	20'-0"	19'-6"	18'-1"	17'-2"	16'-11"	16'-5"	
	2-ply 1-3/4" x 11-7/8"	27'-1"	25'-10"	25'-6"	24'-9"	23'-10"	22'-8"	22'-4"	21'-8"	20'-2"	19'-2"	18'-10"	18'-4"	
	2-ply 1-3/4" x 14"	31'-10"	30'-6"	30'-1"	29'-4"	28'-3"	26'-11"	26'-6"	25'-9"	23'-11"	22'-9"	22'-5"	21'-9"	
Heavyweight Tread	Tread Length		36	42	44	48	36	42	44	48	36	42	44	48
	Tread Length		36	42	44	48	36	42	44	48	36	42	44	48
	1-1/2" x 9-1/4"	14'-5"	13'-9"	13'-6"	13'-2"	13'-5"	12'-9"	12'-7"	12'-2"	11'-8"	11'-1"	10'-11"	10'-7"	
	1-1/2" x 11-1/4"	17'-9"	16'-11"	16'-8"	16'-2"	16'-6"	15'-8"	15'-5"	15'-0"	14'-5"	13'-8"	13'-6"	13'-1"	
	1-3/4" x 11-7/8"	19'-8"	18'-9"	18'-6"	18'-0"	18'-3"	17'-5"	17'-2"	16'-8"	16'-0"	15'-3"	15'-0"	14'-7"	
	1-3/4" x 14"	23'-4"	22'-3"	21'-11"	21'-4"	21'-8"	20'-8"	20'-5"	19'-10"	19'-1"	18'-2"	17'-11"	17'-5"	
	2-ply 1-1/2" x 9-1/4"	17'-11"	17'-1"	16'-11"	16'-5"	16'-8"	15'-11"	15'-8"	15'-3"	14'-8"	13'-11"	13'-9"	13'-4"	
	2-ply 1-1/2" x 11-1/4"	21'-11"	20'-11"	20'-8"	20'-1"	20'-5"	19'-6"	19'-3"	18'-8"	18'-1"	17'-2"	16'-11"	16'-5"	
2-ply 1-3/4" x 11-7/8"	24'-3"	23'-2"	22'-10"	22'-3"	22'-8"	21'-7"	21'-4"	20'-9"	20'-2"	19'-2"	18'-10"	18'-4"		
2-ply 1-3/4" x 14"	28'-7"	27'-4"	27'-0"	26'-4"	26'-9"	25'-6"	25'-2"	24'-6"	23'-11"	22'-9"	22'-5"	21'-9"		

### WET USE

	Tread Length	40 psf Live, 12 psf Tread Dead Load				60 psf Live, 12 psf Tread Dead Load				100 psf Live, 12 psf Tread Dead Load				
		36	42	44	48	36	42	44	48	36	42	44	48	
Lightweight Tread	1-1/2" x 9-1/4"	14'-1"	13'-4"	13'-2"	12'-9"	12'-3"	11'-8"	11'-6"	11'-2"	10'-4"	9'-10"	9'-8"	9'-3"	
	1-1/2" x 11-1/4"	17'-4"	16'-5"	16'-2"	15'-9"	15'-2"	14'-5"	14'-2"	13'-9"	12'-9"	12'-2"	12'-0"	11'-7"	
	1-3/4" x 11-7/8"	19'-3"	18'-4"	18'-1"	17'-6"	16'-10"	16'-0"	15'-10"	15'-4"	14'-3"	13'-7"	13'-4"	13'-0"	
	1-3/4" x 14"	22'-11"	21'-9"	21'-5"	20'-10"	20'-1"	19'-1"	18'-10"	18'-3"	17'-0"	16'-2"	15'-11"	15'-6"	
	2-ply 1-1/2" x 9-1/4"	17'-8"	16'-10"	16'-7"	16'-1"	15'-6"	14'-8"	14'-6"	14'-1"	13'-1"	12'-5"	12'-2"	11'-10"	
	2-ply 1-1/2" x 11-1/4"	21'-9"	20'-8"	20'-4"	19'-9"	19'-0"	18'-1"	17'-10"	17'-4"	16'-1"	15'-3"	15'-1"	14'-7"	
	2-ply 1-3/4" x 11-7/8"	24'-1"	23'-0"	22'-8"	22'-0"	21'-2"	20'-2"	19'-10"	19'-3"	17'-11"	17'-0"	16'-9"	16'-4"	
	2-ply 1-3/4" x 14"	28'-4"	27'-2"	26'-9"	26'-2"	25'-2"	23'-11"	23'-7"	22'-11"	21'-4"	20'-3"	19'-11"	19'-5"	
Heavyweight Tread	Tread Length		36	42	44	48	36	42	44	48	36	42	44	48
	Tread Length		36	42	44	48	36	42	44	48	36	42	44	48
	1-1/2" x 9-1/4"	12'-10"	12'-2"	12'-0"	11'-8"	11'-11"	11'-4"	11'-2"	10'-8"	10'-1"	8'-9"	8'-4"	7'-8"	
	1-1/2" x 11-1/4"	15'-9"	15'-0"	14'-10"	14'-5"	14'-8"	13'-11"	13'-9"	13'-4"	12'-9"	12'-2"	12'-0"	11'-7"	
	1-3/4" x 11-7/8"	17'-6"	16'-8"	16'-5"	16'-0"	16'-3"	15'-6"	15'-3"	14'-10"	14'-3"	13'-7"	13'-4"	13'-0"	
	1-3/4" x 14"	20'-9"	19'-9"	19'-6"	19'-0"	19'-4"	18'-5"	18'-2"	17'-8"	17'-0"	16'-2"	15'-11"	15'-6"	
	2-ply 1-1/2" x 9-1/4"	15'-11"	15'-2"	15'-0"	14'-7"	14'-10"	14'-2"	13'-11"	13'-6"	13'-1"	12'-5"	12'-2"	11'-10"	
	2-ply 1-1/2" x 11-1/4"	19'-6"	18'-7"	18'-4"	17'-11"	18'-2"	17'-4"	17'-1"	16'-8"	16'-1"	15'-3"	15'-1"	14'-7"	
2-ply 1-3/4" x 11-7/8"	21'-7"	20'-7"	20'-4"	19'-10"	20'-2"	19'-3"	18'-11"	18'-5"	17'-11"	17'-0"	16'-9"	16'-4"		
2-ply 1-3/4" x 14"	25'-6"	24'-4"	24'-0"	23'-5"	23'-10"	22'-9"	22'-5"	21'-10"	21'-4"	20'-3"	19'-11"	19'-5"		

**Note:** Not all exterior conditions are wet-use and not all interior conditions are dry use. See [Where do wet use conditions exist at pwtwp.com/resources/Where%20do%20wet%20use%20conditions%20exist](http://www.pwtwp.com/resources/Where%20do%20wet%20use%20conditions%20exist) for more information on this subject.

#### Design Assumptions:

- General guidelines for calculating Step Rise and Run:  
The rise times the run should equal approximately 75". Two times the rise plus one run should equal approximately 25". Rise plus run should be 17" to 18".
- See Product Reports [APA PR-L329](#) and [ICC-ES ESR-2909](#) for design criteria.
- Spans have NOT been limited by the capacity of framing connectors at the stringer to header connection. Connection between the stringer and header to be designed by others.

#### Additional Notes:

- Tables are valid for stairs with a 7-3/4" maximum riser and 10" minimum tread. Consult local building codes for restrictions on riser and tread dimensions.
- Deflection criteria: L/360 live load, and both are L/240 total load.
- Stringers are not stable until treads are securely in place.
- Use of sub-floor adhesive will minimize squeaks.
- A 12' floor-to-floor height (or between landings) is the maximum allowed by code.
- A 1" gap is required between stringers and concrete.
- Refer to the PWT Treated LVL Installation Guide for additional information.

Flashing Tape must be applied to all upward facing surfaces and cut edges

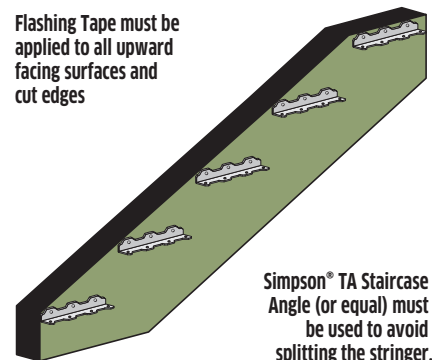

Simpson® TA Staircase Angle (or equal) must be used to avoid splitting the stringer.

# Cut Stringer

## Maximum Horizontal Stringer Run

### DRY USE

40 psf Live, 12 psf Dead Load											
Tread Length	36		42			44			48		
# Stringers	2	3	3	4	5	3	4	5	3	4	5
1-1/2" x 9-1/4"	6'-1"	7'-0"	6'-8"	7'-4"	7'-11"	6'-6"	7'-3"	7'-9"	6'-4"	7'-0"	7'-7"
1-1/2" x 11-1/4"	10'-3"	11'-9"	11'-2"	12'-4"	13'-3"	11'-0"	12'-2"	13'-1"	10'-8"	11'-9"	12'-8"
1-3/4" x 11-7/8"	12'-2"	14'-0"	13'-3"	14'-8"	15'-7"	13'-1"	14'-5"	15'-5"	12'-8"	14'-0"	15'-0"
1-3/4" x 14"	16'-11"	19'-4"	18'-4"	20'-1"	21'-5"	18'-1"	19'-10"	21'-1"	17'-7"	19'-4"	20'-7"
2-ply 1-1/2" x 9-1/4"	7'-9"	8'-10"	8'-5"	9'-2"	9'-9"	8'-3"	9'-1"	9'-8"	8'-0"	8'-10"	9'-5"
2-ply 1-1/2" x 11-1/4"	13'-0"	14'-8"	14'-0"	15'-3"	16'-2"	13'-10"	15'-0"	15'-11"	13'-6"	14'-8"	15'-7"
2-ply 1-3/4" x 11-7/8"	15'-4"	17'-2"	16'-5"	17'-9"	18'-10"	16'-3"	17'-7"	18'-8"	15'-10"	17'-2"	18'-3"
2-ply 1-3/4" x 14"	21'-0"	23'-5"	22'-6"	24'-3"	25'-7"	22'-3"	23'-11"	25'-4"	21'-8"	23'-5"	24'-10"

60 psf Live, 12 psf Dead Load											
Tread Length	36		42			44			48		
# Stringers	2	3	3	4	5	3	4	5	3	4	5
1-1/2" x 9-1/4"	5'-4"	6'-1"	5'-10"	6'-5"	6'-11"	5'-8"	6'-3"	6'-9"	5'-6"	6'-1"	6'-7"
1-1/2" x 11-1/4"	9'-0"	10'-3"	9'-9"	10'-9"	11'-7"	9'-7"	10'-7"	11'-5"	9'-4"	10'-3"	11'-1"
1-3/4" x 11-7/8"	10'-8"	12'-2"	11'-7"	12'-9"	13'-9"	11'-5"	12'-7"	13'-6"	11'-1"	12'-2"	13'-2"
1-3/4" x 14"	14'-9"	16'-11"	16'-0"	17'-8"	19'-0"	15'-9"	17'-4"	18'-9"	15'-4"	16'-11"	18'-2"
2-ply 1-1/2" x 9-1/4"	6'-9"	7'-9"	7'-4"	8'-1"	8'-9"	7'-3"	7'-11"	8'-7"	7'-0"	7'-9"	8'-4"
2-ply 1-1/2" x 11-1/4"	11'-4"	13'-0"	12'-4"	13'-7"	14'-8"	12'-2"	13'-4"	14'-5"	11'-9"	13'-0"	14'-0"
2-ply 1-3/4" x 11-7/8"	13'-5"	15'-5"	14'-8"	16'-2"	17'-4"	14'-5"	15'-11"	17'-1"	14'-0"	15'-5"	16'-8"
2-ply 1-3/4" x 14"	18'-7"	21'-4"	20'-3"	22'-3"	23'-7"	19'-11"	21'-11"	23'-4"	19'-4"	21'-4"	22'-10"

100 psf Live, 12 psf Dead Load											
Tread Length	36		42			44			48		
# Stringers	2	3	3	4	5	3	4	5	3	4	5
1-1/2" x 9-1/4"	4'-6"	5'-2"	4'-11"	5'-5"	5'-9"	4'-10"	5'-4"	5'-8"	4'-8"	5'-2"	5'-6"
1-1/2" x 11-1/4"	7'-7"	8'-8"	8'-3"	9'-1"	9'-9"	8'-1"	8'-11"	9'-7"	7'-11"	8'-8"	9'-4"
1-3/4" x 11-7/8"	9'-0"	10'-4"	9'-9"	10'-9"	11'-7"	9'-8"	10'-7"	11'-5"	9'-4"	10'-4"	11'-1"
1-3/4" x 14"	12'-6"	14'-3"	13'-7"	14'-11"	16'-0"	13'-4"	14'-8"	15'-9"	13'-0"	14'-3"	15'-4"
2-ply 1-1/2" x 9-1/4"	5'-8"	6'-6"	6'-2"	6'-9"	7'-4"	6'-1"	6'-8"	7'-2"	5'-11"	6'-6"	7'-0"
2-ply 1-1/2" x 11-1/4"	9'-7"	10'-11"	10'-5"	11'-5"	12'-4"	10'-3"	11'-3"	12'-2"	9'-11"	10'-11"	11'-9"
2-ply 1-3/4" x 11-7/8"	11'-4"	13'-0"	12'-4"	13'-7"	14'-8"	12'-2"	13'-4"	14'-5"	11'-9"	13'-0"	14'-0"
2-ply 1-3/4" x 14"	15'-8"	17'-11"	17'-0"	18'-9"	20'-3"	16'-9"	18'-6"	19'-11"	16'-4"	17'-11"	19'-4"

**Note:** Not all exterior conditions are wet-use and not all interior conditions are dry use. See *Where do wet use conditions exist* at [pwtewp.com/resources/Where%20do%20wet%20use%20conditions%20exist](http://pwtewp.com/resources/Where%20do%20wet%20use%20conditions%20exist) for more information on this subject.

#### Design Assumptions:

- General guidelines for calculating Step Rise and Run:  
The rise times the run should equal approximately 75". Two times the rise plus one run should equal approximately 25". Rise plus run should be 17" to 18".
- See Product Reports [APA PR-L329](#) and [ICC-ES ESR-2909](#) for design criteria.
- Spans have NOT been limited by the capacity of framing connectors at the stringer to header connection. Connection between the stringer and header to be designed by others.

#### Additional Notes:

- Tables are valid for stairs with an 7-3/4" maximum riser and 10" minimum tread. Consult local building codes for restrictions on riser and tread dimensions.
- Deflection criteria: L/360 live load, and both are L/240 total load.
- Stringers are not stable until treads are securely in place.
- Use of sub-floor adhesive will minimize squeaks.
- A 12' floor-to-floor height (or between landings) is the maximum allowed by code.
- A 1" gap is required between stringers and concrete.
- Refer to the PWT Treated LVL Installation Guide for additional information.

Flashing Tape must be applied to all upward facing surfaces and cut edges

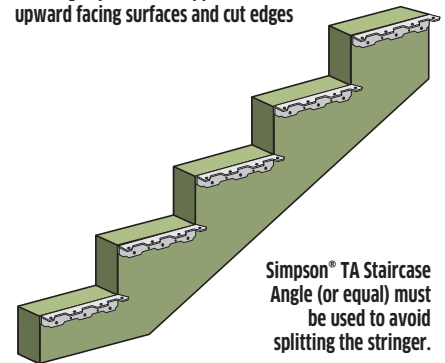

Simpson® TA Staircase Angle (or equal) must be used to avoid splitting the stringer.

# Cut Stringer

## Maximum Horizontal Stringer Run

### WET USE

40 psf Live, 12 psf Dead Load											
Tread Length	36		42			44			48		
# Stringers	2	3	3	4	5	3	4	5	3	4	5
1-1/2" x 9-1/4"	5'-5"	6'-2"	5'-11"	6'-6"	7'-0"	5'-10"	6'-5"	6'-11"	5'-8"	6'-2"	6'-8"
1-1/2" x 11-1/4"	9'-2"	10'-5"	9'-11"	10'-11"	11'-9"	9'-9"	10'-9"	11'-7"	9'-6"	10'-5"	11'-3"
1-3/4" x 11-7/8"	10'-10"	12'-5"	11'-9"	13'-0"	13'-10"	11'-7"	12'-9"	13'-8"	11'-3"	12'-5"	13'-4"
1-3/4" x 14"	15'-0"	17'-2"	16'-4"	17'-10"	19'-0"	16'-1"	17'-7"	18'-9"	15'-7"	17'-2"	18'-3"
2-ply 1-1/2" x 9-1/4"	6'-10"	7'-10"	7'-5"	8'-1"	8'-8"	7'-4"	8'-0"	8'-6"	7'-1"	7'-10"	8'-4"
2-ply 1-1/2" x 11-1/4"	11'-6"	13'-0"	12'-5"	13'-6"	14'-4"	12'-3"	13'-4"	14'-1"	12'-0"	13'-0"	13'-10"
2-ply 1-3/4" x 11-7/8"	13'-7"	15'-2"	14'-7"	15'-9"	16'-8"	14'-5"	15'-7"	16'-6"	14'-1"	15'-2"	16'-1"
2-ply 1-3/4" x 14"	18'-7"	20'-9"	19'-11"	21'-6"	22'-8"	19'-8"	21'-3"	22'-5"	19'-3"	20'-9"	21'-11"

60 psf Live, 12 psf Dead Load											
Tread Length	36		42			44			48		
# Stringers	2	3	3	4	5	3	4	5	3	4	5
1-1/2" x 9-1/4"	4'-2"	5'-5"	5'-2"	5'-8"	6'-1"	5'-0"	5'-7"	6'-0"	4'-8"	5'-5"	5'-10"
1-1/2" x 11-1/4"	8'-0"	9'-2"	8'-8"	9'-7"	10'-3"	8'-7"	9'-5"	10'-1"	8'-4"	9'-2"	9'-10"
1-3/4" x 11-7/8"	9'-6"	10'-10"	10'-4"	11'-4"	12'-2"	10'-2"	11'-2"	12'-0"	9'-10"	10'-10"	11'-8"
1-3/4" x 14"	13'-1"	15'-0"	14'-3"	15'-8"	16'-10"	14'-0"	15'-5"	16'-7"	13'-8"	15'-0"	16'-2"
2-ply 1-1/2" x 9-1/4"	6'-0"	6'-10"	6'-6"	7'-2"	7'-9"	6'-5"	7'-1"	7'-7"	6'-2"	6'-10"	7'-4"
2-ply 1-1/2" x 11-1/4"	10'-1"	11'-6"	10'-11"	12'-0"	13'-0"	10'-9"	11'-10"	12'-9"	10'-5"	11'-6"	12'-5"
2-ply 1-3/4" x 11-7/8"	11'-11"	13'-8"	13'-0"	14'-4"	15'-4"	12'-9"	14'-1"	15'-2"	12'-5"	13'-8"	14'-9"
2-ply 1-3/4" x 14"	16'-6"	18'-11"	17'-11"	19'-9"	20'-11"	17'-8"	19'-5"	20'-8"	17'-2"	18'-11"	20'-2"

100 psf Live, 12 psf Dead Load											
Tread Length	36		42			44			48		
# Stringers	2	3	3	4	5	3	4	5	3	4	5
1-1/2" x 9-1/4"	2'-10"	4'-1"	3'-7"	4'-7"	5'-2"	3'-5"	4'-4"	5'-1"	3'-2"	4'-1"	4'-11"
1-1/2" x 11-1/4"	6'-1"	7'-9"	7'-4"	8'-1"	8'-8"	7'-3"	7'-11"	8'-7"	6'-9"	7'-9"	8'-4"
1-3/4" x 11-7/8"	8'-0"	9'-2"	8'-8"	9'-7"	10'-3"	8'-7"	9'-5"	10'-2"	8'-4"	9'-2"	9'-10"
1-3/4" x 14"	11'-1"	12'-8"	12'-1"	13'-3"	14'-3"	11'-10"	13'-0"	14'-0"	11'-6"	12'-8"	13'-8"
2-ply 1-1/2" x 9-1/4"	5'-0"	5'-9"	5'-6"	6'-0"	6'-6"	5'-5"	5'-11"	6'-5"	5'-3"	5'-9"	6'-2"
2-ply 1-1/2" x 11-1/4"	8'-6"	9'-8"	9'-3"	10'-2"	10'-11"	9'-1"	10'-0"	10'-9"	8'-10"	9'-8"	10'-5"
2-ply 1-3/4" x 11-7/8"	10'-1"	11'-6"	10'-11"	12'-0"	13'-0"	10'-9"	11'-10"	12'-9"	10'-6"	11'-6"	12'-5"
2-ply 1-3/4" x 14"	13'-11"	15'-11"	15'-2"	16'-8"	17'-11"	14'-11"	16'-5"	17'-8"	14'-6"	15'-11"	17'-2"

**Note:** Not all exterior conditions are wet-use and not all interior conditions are dry use. See *Where do wet use conditions exist* at [pwtewp.com/resources/Where%20do%20wet%20use%20conditions%20exist](http://pwtewp.com/resources/Where%20do%20wet%20use%20conditions%20exist) for more information on this subject.

#### Design Assumptions:

- General guidelines for calculating Step Rise and Run:  
The rise times the run should equal approximately 75". Two times the rise plus one run should equal approximately 25". Rise plus run should be 17" to 18".
- See Product Reports [APA PR-L329](#) and [ICC-ES ESR-2909](#) for design criteria.
- Spans have NOT been limited by the capacity of framing connectors at the stringer to header connection. Connection between the stringer and header to be designed by others.

#### Additional Notes:

- Tables are valid for stairs with an 7-3/4" maximum riser and 10" minimum tread. Consult local building codes for restrictions on riser and tread dimensions.
- Deflection criteria: L/360 live load, and both are L/240 total load.
- Stringers are not stable until treads are securely in place.
- Use of sub-floor adhesive will minimize squeaks.
- A 12' floor-to-floor height (or between landings) is the maximum allowed by code.
- A 1" gap is required between stringers and concrete.
- Refer to the PWT Treated LVL Installation Guide for additional information.

Flashing Tape must be applied to all upward facing surfaces and cut edges

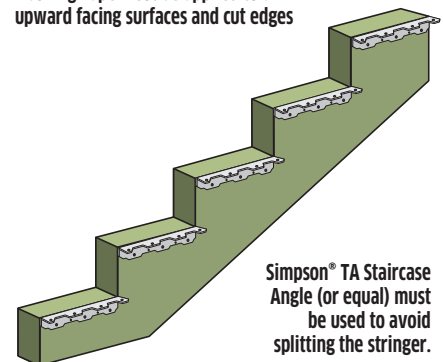

Simpson® TA Staircase Angle (or equal) must be used to avoid splitting the stringer.

## Flashing or approved flashing tape is required on any upward-facing surfaces and all notch surfaces

- PWT Treated LVL is treated throughout the piece (no gradient), "re-treatment" is not necessary.
- PWT Treated LVL is lightly sealed to reduce the amount of moisture that is absorbed prior to installation.
- **Coating ends with flashing, a sealer, or paint is highly recommended.**
- ANCHOR Seal® is an example of product specifically designed for sealing end cuts.
- Do not wrap strair stringers with moisture-trapping materials.
- Flashing tape must meet the following standards to protect PWT Treated LVL
  1. AAMA 711-22 or
  2. All of the following ASTM standards
    - a. ASTM D1970 for water penetration around fasteners
    - b. ASTM G154/155 for exposure to UV
    - c. ASTM D3330 Method F for elevated temperature exposure
- Flashing tape must be installed per the manufacturer's instructions and as required by code.
- Flashing tape warranty must meet or exceed the PWT Treated LVL warranty to ensure the PWT Treated LVL is adequate protected for the duration of the PWT warranty.

**Flashing Tape must be applied to all upward-facing surfaces and cut edges**

Scan this QR code for a list of products that meet these requirements.

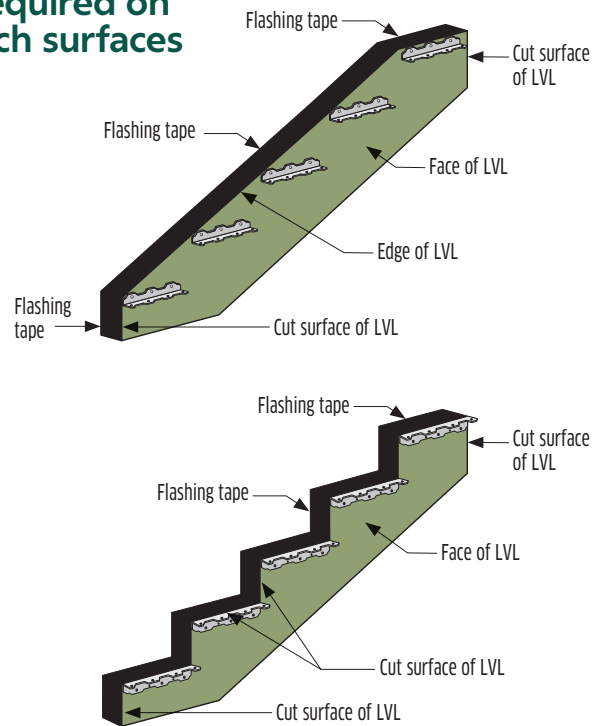

### G1 TOP SUPPORT – LEDGER

Provide restraint to ensure stringer lateral stability

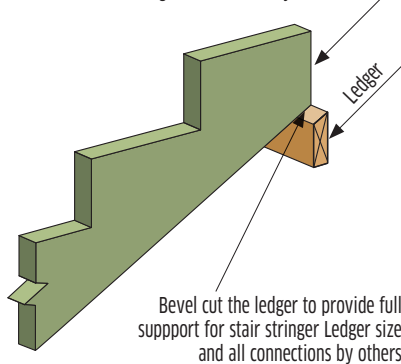

### G2 TOP SUPPORT – CONNECTOR

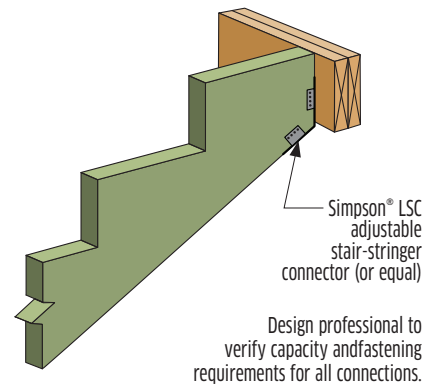

### G3 BOTTOM SUPPORT – CONCRETE

Min. 2x4 let-in block connected to the plate below

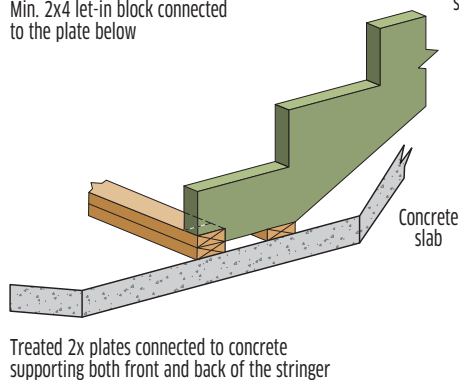

Bottom of column must be 1" above concrete and 8" above grade. Flashing is required on facing all upward surfaces (not always shown for clarity)

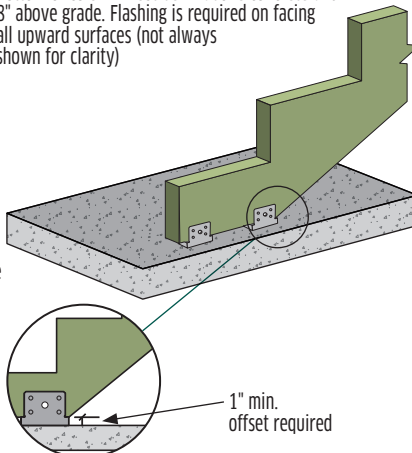

Use of Stair Tread Connectors are required for all Stringers

Simpson® TA Staircase Angle (or equal) must be used to avoid splitting the stringer.

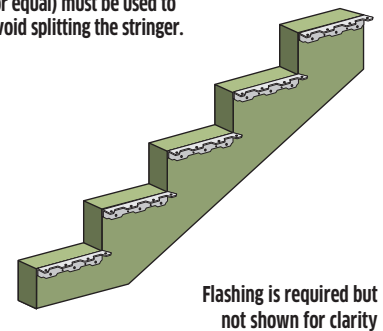

Flashing is required but not shown for clarity

# Warnings

The following conditions are NOT permitted!

Do not use visually damaged products without first checking with your local PWT distributor or call (800) 515-7570.

<b>R9</b> <b>DON'T</b> bore holes or notch other than for the stair tread.	<b>R10</b> <b>DON'T</b> overcut stair stringers.	<b>R11</b> <b>DON'T</b> partially support stair stringers—top	<b>R12</b> <b>DON'T</b> partially support stringers—bottom	<b>R13</b> <b>DON'T</b> install nails or screws too close to the ends.

## Proper connectors and fasteners

Appropriate connectors and fasteners must be used for the conditions-of-use to avoid failure due to corrosion or overloading.

In all exterior applications or any other conditions where excess moisture is present, high quality, exterior grade, stainless steel or hot dipped galvanized or durable grade fasteners are required.

### SCREWS – PREDRILL ALL SCREWS THAT SECURE STAIR TREADS

MINIMUM DISTANCE DETAILS (IN) SIMPSON SCREWS		MINIMUM DISTANCE DETAILS (IN) NAILS	
<p><b>Edge Distances</b></p> <p>SDVV Only</p> <p>Min. 1" between rows</p> <p>*Predrill using the appropriate diameter as defined by the manufacturer.</p> <p><b>Note:</b></p> <ol style="list-style-type: none"> <li>Screws not covered by this detail are outside the scope of this document.</li> <li>Screw edge distances, end distances, and spacing must be sufficient to prevent splitting of the wood, or as required by this detail, whichever is the more restrictive.</li> <li>Stagger nails each row relative to the adjacent rows (parallel to the LVL grain) so that there is a minimum distance parallel to the grain of 0.5".</li> </ol>	<p><b>Face Distances</b></p> <p>SD9, SD10</p> <p>SD18, SDS25</p> <p>SD22, SDWS (Ext)</p> <p>Not To Scale</p> <p>13/16" for SD9, SD10</p> <p>3" for SWD18, SDS25</p> <p>4" for SWD22, SDWS (Ext)</p>	<p><b>Edge Distances</b></p> <p>Diam. &lt;= 0.120"</p> <p>0.120" &lt; Diam. &lt;= 0.162"</p> <p>All Nails</p>	<p><b>Face Distances</b></p> <p>Diam. &lt;= 0.148"</p> <p>Diam. &lt;= 0.162"</p> <p>All Nails</p> <p>Min. 1" between rows</p>
<p>Scan this QR code to access the Connector Sizes and Distances Tech Note.</p>		<p>*Predrill with a diameter that is 90% the diameter of the nail.</p> <p><b>Note:</b></p> <ol style="list-style-type: none"> <li>Nail sizes not covered by this detail are outside the scope of this document.</li> <li>Nail edge distances, end distances, and spacing must be sufficient to prevent splitting of the wood, or as required by this detail, whichever is the more restrictive.</li> <li>Stagger nails each row relative to the adjacent rows (parallel to the LVL grain) so that there is a minimum distance parallel to the grain of 0.5".</li> </ol>	

**IMPORTANT NOTE:** It is imperative that PWT Treated LVL remains protected from precipitation and high humidity until it is installed. PWT Treated LVL has a moisture content of 6-8% when it leaves the factory. Once installed and flashed as stated in the installation guidelines, PWT Treated LVL will remain dimensionally stable for many years to come.

# Reference Design Values

## DRY USE – 100% LOAD DURATION

2.0E 2800Fb PWT Treated LVL	Dry Use (psi)	Wet Use (psi)
Modulus of Elasticity, $E^{(1)}$ =	2.0	1.4
Bending (beam), $F_b^{(2)}$ =	2,800	1,680
Horizontal Shear (beam), $F_v$ =	285	160
Compression perpendicular to grain [psi], $F_c^{(1)}$ =	850	465

- Do not adjust for load duration.
- For Beam Orientation adjust by  $(12/d)^{0.2}$ , where  $d$  is the depth of the member [inches].
- Deformations up to 0.125" could occur in the tabulated value in wet use conditions
- Dry use (dry service) for structural composite lumber products refers to an application where the in-service equilibrium moisture content of wood is less than 16%.

## SYSTEM COMPARISON

Features	PWT Treated LVL	Ordinary Pressure-Treated Lumber
25-Year Warranty	YES	Varies
Ability to Stain at Time of Installation	YES	Limited Results
Available in Long Lengths	YES	NO
Consistent Dimension (No Planing)	YES	NO
Interior Use	YES	NO

See *Where do wet use conditions exist* at [pwtewp.com/resources/Where%20do%20wet%20use%20conditions%20exist](http://pwtewp.com/resources/Where%20do%20wet%20use%20conditions%20exist) for more information on this subject.



## Product Highlights

- PWT Treated LVL is the only manufacturer-treated LVL, and it is covered by a 25-year limited, transferable warranty.
- PWT Treated LVL is protected against damage caused by fungal rot, decay, and wood-destroying insects, including Formosan termites (interior or exterior usage).
- We use a proprietary and CODE APPROVED treatment system and process, utilizing TRU-CORE® technology.
- May be designed for either dry and wet use.

## Features and Benefits

- Non-corrosive!
  - PWT Treated LVL and its chemical additive do not corrode or damage hardware.
  - Choose appropriate coating on connectors for the project conditions.
- Interior use allowed
- Stainable and paintable
- No added VOCs
- Properties for PWT Treated LVL are available in [APA PR-L329](#) and [ICC-ES ESR-2909](#)

## The Product

- PWT Treated LVL is rated for use in above ground (UC3B) and non-ground contact applications including components that are difficult to maintain, repair, or replace and that are critical to the performance and safety of the entire system:
  - Exterior and interior
  - Deck substructures, sill plates, and fascia
- Treatment is added during the LVL manufacturing process, which fully penetrates throughout each veneer layer, offering complete protection from the inside out
- No treatment gradient – and double (2X) the preservative retention required in various standards around the world
- Additionally, envelope treated for best surface properties
- Meets FEMA Flood Damage-Resistant Materials Requirements for Class 4

## Storage and Maintenance Guidelines

### Storage

- Store bundles with wood lying in flat orientation on a smooth, level, well-drained and supportive surface.
- Bundles should not be in contact with the ground.
- Place 2x or LVL spacers (at a maximum of 10' apart) between bundles and the ground and bundles stored on top of one another.

**Bundles should remain wrapped, strapped and protected from the weather until time of installation.**

### Maintenance in exterior applications (including, but not limited to, deck substructures)

- PWT Treated™ LVL must not be installed or become in contact with the ground in use in a structure.
- Regular efforts must be made to remove debris buildup around wood members, metal connectors, and fasteners.
- Mold, fungi, and mildew cause discoloration of the wood surface (commonly appearing as a colored, fuzzy, or powdery surface growth) that can quickly spread over surfaces with high moisture levels.
- Mold and mildew will not impact the strength or stiffness of a wood member, but the presence of mold indicates a high moisture condition.
- Excessive moisture content for long periods can cause damage to any exterior-use wood product.

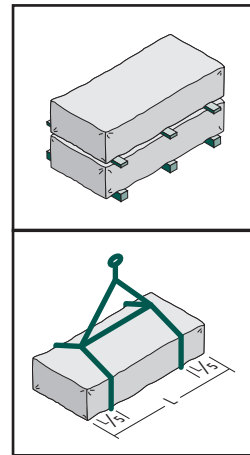

1850 Park Lane Burlington, WA 98233  
 TF 888.707.2285 [pwtewp.com/treated](http://pwtewp.com/treated)

For product catalog and complete warranty details or for more information on the full line of PWT products or the nearest distributor, visit [pwtewp.com/treated](http://pwtewp.com/treated).

PWT Treated LVL is manufactured in the United States.

**⚠ CAL. PROP 65 WARNING:** Drilling, sawing, sanding or machining wood products can expose you to wood dust, a substance known to the State of California to cause cancer. Avoid inhaling wood dust or use a dust mask or other safeguards for personal protection. For more information go to [www.P65Warnings.ca.gov/wood-dust](http://www.P65Warnings.ca.gov/wood-dust).

© 2026 Pacific Woodtech Corporation. All rights reserved. APA, APA Rated, and APA Product Report are registered trademarks of APA – The Engineered Wood Association. PWT™ is a registered trademark of Pacific Woodtech Corporation. Printed in USA. Specifications (details) subject to change without notice.

NOTE: PWT periodically updates and revises its product information. To verify that this version is current, contact the nearest sales office, visit [pwtewp.com](http://pwtewp.com), or call 888.707.2285.